

MONTGOMERY TOWNSHIP BOARD OF EDUCATION

1014 ROUTE 601

SKILLMAN, NEW JERSEY 08558

SEALED BID

**B22-02, Annual Boiler Cleaning, Inspection and Service with a
Time and Material Contract**

Previous Bidder Information:

| | | |
|---------------------------|---------------------------------------|-------------|
| <u>Vendor</u> | | |
| Kelin Heating & A/C, Inc. | Grand Total for Boiler, Cleaning | \$10,990.00 |
| 15 Columbia Avenue | Inspection and Service | |
| Colonia, NJ 07067 | Hourly Rate - 8:00 A.M. to 5:00 P.M.: | \$80.00 |
| | After Hours & Saturday: | \$120.00 |
| | Sunday & Holidays: | \$120.00 |
| | Discount Off List: | 12% |

**MONTGOMERY TOWNSHIP BOARD OF EDUCATION
NOTICE TO BIDDERS**

The Montgomery Township Board of Education will accept sealed bids until **9:00 A.M. on Tuesday, June 22, 2021**, and will be publicly opened and read thereafter in the office of the School Business Administrator/Board Secretary, Administration Building, 1014 Route 601, Skillman, New Jersey, 08558, for the following:

B22-02, Annual Boiler Cleaning, Inspection and Service with a Time and Material Contract

The bid package may be examined at the office of the School Business Administrator/Board Secretary as stated above and each bidder, thereof, may obtain one copy. Requests may be made to (609) 466-7635 or the District Homepage, www.mtsd.k12.nj.us, click-on Departments/Business Office/Bids.

Due to the Coronavirus (COVID-19) the Montgomery Township Board of Education is requesting that all bidders deliver or have their bids delivered to the **“lockbox”** at door labeled **AD41** at the Administration Building, If the bidder delivers their bid via UPS, FedEx etc. it must be delivered **“Signed Receipt Not Required”** because no one will be available to receive bids. Further details can be found on the District Homepage, www.mtsd.k12.nj.us, click-on Departments/Business Office/Bids.

Bids must be submitted on the standard proposal form in the manner designated therein and required by the specifications. Bids must be enclosed in sealed envelopes bearing the name of the bidder on the outside, **clearly marked with the bid description and bid number**, and addressed to Alicia M. Schauer, School Business Administrator/Board Secretary of the Montgomery Township Board of Education, 1014 Route 601, Skillman, New Jersey 08558. Sealed bids must be delivered to the Administration Building on or before the time and date stated above. The Montgomery Township Board of Education assumes no responsibility for bids mailed incorrectly or misdirected in delivery.

Bidders shall submit with the bid a certified check, cashier's check or bid bond in the amount of ten percent (10%) of the total price bid, over \$2,000.00 but not in excess of \$20,000, payable to the Montgomery Township Board of Education. Each bidder is required to submit with its bid a Consent of Surety certificate with Power of Attorney for full amount of bid price from a Surety Company licensed and authorized to do business in the State of New Jersey and acceptable to the owner stating that it will provide said bidder with a Performance and Payment Bond in the full amount of the bid.

No bidder may withdraw his bid for a period of sixty (60) days after the date set for the opening thereof.

Bidders are required to comply with the Affirmative Action requirements of N.J.S.A. 10:5-31 et seq. and N.J.A.C. 17:27. If applicable the bidders are required to comply with the Prevailing Wage Law as required under Chapter 150 of the laws of 1963, State of New Jersey.

Bidding shall be in conformance with the applicable requirements of N.J.S.A. 18A:18A-1 et seq., pertaining to the **“Public School Contracts Law”**.

Alicia M. Schauer
School Business Administrator/Board Secretary
June 10, 2021

MONTGOMERY TOWNSHIP BOARD OF EDUCATION
1014 ROUTE 601
SKILLMAN, NEW JERSEY 08558
PHONE: (609) 466-7601
FAX: (609) 466-0944

B22-02, Annual Boiler Cleaning, Inspection and Service with a Time and Material Contract

Instructions to Bidder

General

The intent of this specification is to establish minimum requirements upon which solicitation of bids will be accepted for Board of the annual boiler cleaning, inspection and service with a time and material contract including parts and supplies as needed for the Montgomery Township Education. These specifications for the provision or performance of goods or services have been drafted in a manner to encourage free, open and competitive bidding.

The Montgomery Township Board of Education will accept sealed bids until **9:00 A.M.** on **Tuesday, June 22, 2021**, in the office of the School Business Administrator/Board Secretary, Administration Building, 1014 Route 601, Skillman, New Jersey, 08558 Bids must be submitted on the standard proposal form in the manner designated therein and required by the specifications. Bids must be enclosed in sealed envelopes bearing the name of the bidder on the outside, clearly marked with the bid description and bid number, and addressed to Alicia M. Schauer, School Business Administrator/Board Secretary of the Montgomery Township Board of Education, 1014 Route 601, Skillman, New Jersey 08558. No bids, under any circumstances shall be accepted after the stated time in the "Advertisement". Any bidder who mails their bid accepts responsibility for any delay in delivery, including, but not limited to, delivery to wrong address.

Due to the Coronavirus (COVID-19) the Montgomery Township Board of Education is requesting that all bidders deliver or have their bids delivered to the **"lockbox"** at door labeled **AD41** at the Administration Building. If the bidder delivers their bid via UPS, FedEx etc. it must be delivered "Signed Receipt Not Required" because no one will be available to receive bids. Further details can be found on the District Homepage, www.mtsd.k12.nj.us, click on Departments/Business Office/Bids.

The bid opening will be held remotely. If you would like to attend the remote bid opening please contact Alicia M. Schauer, School Business Administrator at aschauer@mtsd.us. A link will be forwarded to you prior to the bid opening.

The bidder is required to complete all spaces called for on the proposal form. Omission of any information will result in the bidder's proposal being considered as non-responsive.

At the time of the opening of the bids, each bidder will be presumed to have examined and to be thoroughly familiar with the specifications (including all Addenda). The failure of or omission of any bidder to receive or examine the instruction documents or specifications, the work to be performed and materials to be furnished shall in no way relieve such bidder from obligation in respect to the bid. No consideration will be given for any misunderstanding as to the work, cost, and materials required, it being mutually understood that the tender of the bid carries with it agreement to this and other obligations set forth in the specifications and requirements.

Bid prices are firm and cover the period as designated on the Proposal Form. The contract will be awarded to the responsible bidder submitting the lowest proposal complying with the conditions of the specifications, provided their bid is reasonable and it is to the interest of the Board of Education to accept it. The bidder to whom the award is made will be notified at the earliest practical date.

The Board of Education reserves the right to reject bids pursuant to N.J.S.A. 18A:18A-22. Bidders are required to comply with the requirements of the Public Schools Contracts Law, N.J.S.A. 18A:18A-1, et seq., P.L. 1975, C. 127 (N.J.A.C. 17.27),

Interpretation and Addenda

Clarifications, request for interpretation or questions will be accepted no later than ten (10) days, Saturday, Sundays, or holidays excepted, prior to the date for the acceptance of bids and shall be forwarded to Alicia M. Schauer, School Business Administrator/Board Secretary, Montgomery Township Board of Education, 1014 Route 601, Skillman, New Jersey, 08558. Any and all such clarifications, interpretations, answers to questions and any supplemental instructions will be sent in the form of written addenda to the specifications to any person who submitted a bid or who has received a bid package in one of the following ways (a) in writing by certified mail, (b) by certified facsimile transmission, meaning that the sender's facsimile machine produces a receipt showing date and time of transmission and that the transmission was successful or (c) by a delivery service that provides certification of delivery to the sender.

Notice of all addendums shall be published no later than seven (7) days, Saturday, Sundays and holidays excepted, prior to the date for acceptance of bids, in an official newspaper of the Montgomery Township Board of Education and be provided to any person who submitted a bid or who has received a bid package will be forwarded to the prospective bidders in one of the following ways (a) in writing by certified mail, (b) by certified facsimile transmission, meaning that the sender's facsimile machine produces a receipt showing date and time of transmission and that the transmission was successful or (c) by a delivery service that provides certification of delivery to the sender (N.J.S.A. 18A:18A-21 c. 1).

Failure of any bidder to whom addenda is sent fails to receive such addenda shall not relieve any bidder from any obligation under his bid submitted; all addenda so issued shall become part of the contract document. Failure of the Montgomery Township Board of Education to obtain a receipt when good faith notice is sent or delivered to the address or telephone facsimile number on file shall not be considered failure by the Board of Education to provide notice.

Challenges

Any prospective bidder who wishes to challenge a bid specification shall file such challenges in writing with Alicia M. Schauer, School Business Administrator/Board Secretary, Montgomery Township Board of Education, 1014 Route 601, Skillman, New Jersey, 08558, no less than three (3) business days prior to the opening of bids. Challenges filed after that time shall be considered void and have no impact on the Board of Education or the award of a contract (N.J.S.A. 18A:18A-15).

Qualifications of the Service Company

The contractor shall be an insured, licensed, qualified company in the State of New Jersey to perform this service in institutional facilities and shall conform to all Federal, State, and Local codes as prescribed and shall have the capability of 24 hours a day 365 days a year service. This requirement applies to any and all subcontractors who may be used by the contractor for this project. The contractor shall provide to the Montgomery Township Board of Education a list of at least three (3) references from sites where they have completed similar work with their bid.

The Montgomery Township Board of Education may make additional investigation, as it deems necessary to determine the ability of the contractor to perform the work. The contractor shall furnish to the Board of Education all such information for this purpose as the Board of Education may request. The Board of Education reserves the right to reject any bid if the evidence submitted by, or investigation of, such contractor fails to satisfy the obligations of the contract or to complete the work contemplated therein.

American Goods, Brand Names, Proprietary Goods or Services, Etc.

All contracts for work for which the Montgomery Township Board of Education will pay any part of the cost or work which by contract will ultimately own and maintain, that only manufactured and farm products of the United States, wherever available, be used in such work (N.J.S.A.18A:18A-20).

Whenever a “brand name” is stated in all cases “brand name or equivalent” is implied except that if the goods or services to be provided or performed are proprietary, such goods or services may be purchased stipulating the proprietary goods or services in the bid specification when the special need for such copyrighted proprietary goods or services is directly related to the performance, completion or undertaking of the purpose for which the contract is to be awarded (N.J.S.A.18A:18A-15).

In the performance of the work the bidder and all subcontractors shall use domestic materials. But if the Montgomery Township Board of Education finds that in respect to some particular domestic materials it is impracticable to make such requirement or that it would unreasonably increase the cost, an exception shall be granted.

Laws

The bidder shall comply with all applicable laws, statutes, regulations, and ordinances and any order issued by any governmental entity. The parties’ contract shall be governed by the laws of the State of New Jersey.

The bidder shall maintain all documentation related to products, transactions or services under the contract for a period of five (5) years from the date of final payment. Such records shall be made available to the New Jersey Office of the State Comptroller upon request (N.J.S.A. 52:15C-10/N.J.A.C. 17:44-2.2).

Insurance Requirements

The bidder shall maintain the following insurance in force and effect for the term and the life of the contract. These coverages shall be maintained either through insurance policies from insurance companies licensed to do business in the State of New Jersey and rated as A or better as determined by A.M. Best Company or through formal, fully funded self-insurance programs authorized by law and acceptable to the Montgomery Township Board of Education. All policies shall incorporate a provision requiring the giving of written notice to the Montgomery Township Board of Education by certified mail, return receipt requested, at least thirty (30) days prior to the cancellation or non-renewal of any such policies.

Commercial general liability insurance covering any and all bodily injury, property damage or personal injury arising out of or in connection with the work performed by the bidder or subcontractors as well as an umbrella excess liability insurance. Comprehensive automobile liability insurance including coverage for any and all owned, non-owned, hired or borrowed vehicles covering bodily injury and property damage.

Commercial General Liability Insurance

The bidder must maintain Commercial General Liability Insurance, covering any and all Bodily Injury, Property Damage or Personal Injury arising out of or in connection with the work performed by the bidder or its subcontractors. The policy shall include coverage for blanket contractual liability, products, completed operations, explosion, collapse and underground operations in an amount not less than \$1,000,000.00 Bodily Injury and Property Damaged Combined Single Limit Each Occurrence with a \$2,000,000 General Aggregate. Further, the policy shall include an “Aggregate Limit per Project” extension.

Comprehensive Automobile Liability Insurance

All contracted parties must maintain Commercial Automobile Liability Insurance, including coverage for any and all owned, non-owned, hired or borrowed vehicles, covering Bodily Injury and Property Damage. Such coverage shall be in the amount of \$1,000,000.00 Bodily Injury and Property Damage Combined Single Limit Each Accident.

Worker's Compensation Insurance

The bidder and all subcontractors must maintain Worker's Compensation Insurance in accordance with the laws of the State of New Jersey and any other jurisdiction required to protect employees of any and all contracted parties who will engage in the performance of work.

- A. Worker's Compensation Statutory
- B. Employer's Liability \$500,000.00 each accident

Umbrella Excess Liability Insurance

The bidder must maintain Umbrella Excess Liability Coverage that will be excess of the primary General Liability, Automobile Liability, Workers Compensation Employer's Liability. Such coverage will be in the amount of \$2,000,000 Bodily Injury and Property Damaged Combined Single Limit of Liability Each Occurrence/General Aggregate.

Prior to the commencement of services, the bidder shall furnish a certificate of insurance covering Commercial General Liability, Comprehensive Automobile Liability and Umbrella Excess Liability naming the Montgomery Township Board of Education, its employees, agents and assigns as "Additional Insured". The successful bidder shall provide coverage so that all insurance coverage must be in effect no later than 12:01 A.M. EST at the start of the day of the contract and remain in effect for the duration of the contract, including any extensions. A sample of insurance must be included with your proposal.

Award

The contract will be awarded to the responsible bidder submitting the lowest proposal complying with the conditions of the Specifications, provided their bid is reasonable and it is to the interest of the Board to accept it. Awards shall be made on each item, and group of items or for the entire bid, whichever the Board deems as being in its best interest. The bidder to whom the award is made will be notified at the earliest practical date.

Payment

The terms of payment, under which bids are solicited and to which all contractors offering proposals under these specifications agree, are: Net cash upon proper presentation of the amount stated in the contract and covered by formal order and necessary action by the Board of Education. Billings are to be made for only that part of the order, which is completed.

Indemnification

To the fullest extent permitted by law, the bidder shall indemnify and hold harmless the owner, its agents and employees from and against any and all claims, damages, losses and expenses, including but not limited to attorneys' fees and cost of litigation, arising out of or resulting from any and all acts of the bidder, its employees, agents, and subcontractors related to the services the bidder provides to the Board in accordance with these specifications. Such obligation shall not be construed to negate, abridge or reduce other rights or obligations of indemnity which would otherwise exist as to a party or person described in this paragraph. The Board may defend itself, at the bidder's expense, from any claim or lawsuit which may arise out of the bidder's performance or lack of performance under the terms of the agreement or the Board may elect to have the bidder provide the Board with legal representation at the bidder's own expense. This provision shall survive the termination of the agreement.

In claims against any person or entity indemnified under this paragraph by an employee of the bidder, a subcontractor, anyone directly or indirectly employed by them or anyone for whose acts they may be liable, the indemnification obligation under this paragraph shall not be limited by a limitation on amount or type of damages, compensation or benefits payable by or for the bidder or a subcontractor under worker's compensation acts, disability benefit acts or other employee benefit acts.

Termination of Contract

If, through any cause, the successful bidder shall fail to fulfill in a timely and proper manner obligations under this contract or if the bidder shall violate any of the requirements of this contract the Board has the right to terminate the agreement, without cause, by providing the successful bidder with thirty (30) days prior written notice. Such termination shall relieve the owner of any obligation for balances to the bidder of any sum or sums set forth in the contract. Notwithstanding the bidder shall not be relieved of liability of the owner for damages sustained by the owner by virtue of any breach of the contract by the bidder and the owner may withhold payments to the bidder for the purpose of compensation until such time as the exact amount of the damage due the owner from the bidder is determined.

The bidder agrees to indemnify and hold the owner harmless from any liability to subcontractors/suppliers concerning payment for work performed or goods supplied arising out of the lawful termination of the contract by the owner under this provision.

In the case of default by the successful bidder, the owner may procure the articles or services from other sources and hold the successful bidder responsible for the excess cost.

Statutory and Other Requirements

Mandatory Affirmative Action Certification

No firm may be issued a contract unless it complies with the affirmative action provisions of N.J.S.A. 10:5-31 et seq. and N.J.A.C. 17:27-1 et seq. as administered by the Division of Purchase & Property Contract Compliance and Audit Unit (Division) and provided below. The contract will include the language included as Exhibit A in this specification.

Goods, Professional Services and General Service Contracts

Each contractor shall submit to the public agency, after notification of award but prior to execution of a goods and services contract, one of the following three documents:

1. A Letter of Federal Approval indicating that the contractor is under an existing federally approved or sanctioned affirmative action program. A copy of the approval letter must be provided by the contractor to the Public Agency and the Division. This approval letter is valid for one year from the date of issuance.
2. A Certificate of Employee Information Report (hereafter "Certificate"), issued in accordance with N.J.A.C. 17:27 et seq. The contractor must provide a copy of the Certificate to the Public Agency as evidence of its compliance with the regulations. The Certificate represents the review and approval of the contractor's Employee Information Report, Form AA-302 by the Division.
3. The successful contractor shall complete an Initial Employee Report, Form AA-302 and submit it to the Division with a check or money order for \$150.00 made payable to "Treasurer, State of NJ" and forward a copy of the Form to the Public Agency. Upon submission and review by the Division, the Report shall constitute evidence of compliance with the regulations.

Americans with Disabilities Act of 1990

The Act prohibits discrimination on the basis of disability by public entities in all services, programs and activities provided or made available by public entities. If awarded the contract, the contractor is required to comply with requirements related to the Americans with Disabilities Act as provided in this specification. The contractor is obligated to comply with the Act and to hold the owner harmless for any violations committed under the contract.

New Jersey Anti-Discrimination

The contract for this proposal shall require, if the bidder is awarded a contract or subcontract for the purposes of the contract, the bidder or anyone working for the bidder or contractor or subcontractor, agrees that they will not discriminate against any person who is qualified and ready to perform the work or, by reason of race, creed, color, national origin, ancestry, marital status, gender identity or expression, affectional or sexual orientation or sex and agrees to abide by all anti-discrimination laws including but not limited to N.J.S.A. 10:2-1 as provided in this specification, New Jersey Anti-Discrimination Provisions N.J.S.A. 10:2-1 et seq.

Bid Security/Guarantee; Bid Bond, Cashier's Check or Certified Check

Bidder shall submit with the bid a certified check, cashier's check or bid bond in the amount of ten percent (10%) of the total price bid, but not in excess of \$20,000, payable to the Montgomery Township Board of Education.

When submitting a Bid Bond, it shall contain Power of Attorney for full amount of Bid Bond from a surety company authorized to do business in the State of New Jersey. All bid bonds submitted must be signed and witnessed with original signatures. The Montgomery Township Board of Education will not accept facsimile or rubber stamp signatures on the bid bond. Failure to sign the bid bond by either the Surety or Principal shall be deemed cause for rejection of the bid. The Attorney-in-Fact who executes the bond on behalf of the surety shall affix to the bond a certified and current copy of the Power of Attorney. (Please note: The name, address and phone number of the Bond Underwriter as well as the Bond Number shall be included with all bonds submitted to the Montgomery Township Board of Education.)

The check or bond of the unsuccessful bidder(s) shall be returned pursuant to N.J.S.A. 18A:18A-36. The check or bond of the bidder to whom the contract is awarded shall be retained until a contract is executed and the required performance bond or other security is submitted. The check or bond of the successful bidder shall be forfeited if the bidder fails to enter into a contract pursuant to N.J.S.A. 18A:18A-24.

Failure to submit a bid guarantee shall result in rejection of the bid. Uncertified business checks, personal checks or money orders are not acceptable and shall also result in rejection of the bid.

Consent of Surety

Each bidder is required to submit with its bid a Consent of Surety certificate with Power of Attorney for full amount of bid price from a Surety Company licensed and authorized to do business in the State of New Jersey and acceptable to the owner stating that it will provide said bidder with a Performance Bond in the full amount of the bid. This certificate shall be obtained in order to confirm that the bidder to whom the contract is awarded will furnish Performance and Payment Bonds from an acceptable surety company on behalf of said bidder, which results in performance security equal to the total amount of the contract, pursuant to N.J.S.A. 18A:18A-25.

Failure to submit consent of surety form shall result in rejection of the bid.

Statement of Ownership Disclosure Certification

N.J.S.A. 52:25-24.2 provides that no business organization, regardless of form of ownership shall be awarded any contract for the performance of any work or the furnishing of any goods and services, including construction bids, unless, prior to the receipt of the bid or accompanying the bid of said business organization, bidders shall submit a statement setting forth the names and addresses of all persons and entities that own ten percent or more of its stock or interest of any type at all levels of ownership. The disclosure shall be continued until names and addresses of every noncorporate stockholder, and individual partner, and member, exceeding the ten percent ownership, has been listed. Disclosure must also be provided for individual stockholders who own more than 10 percent, if the business is owned by a publicly owned corporation. In this case, disclosure is met by providing a web link or reference to a US Security Exchange Commission (or similar foreign regulator for a non-US corporation) ownership filing statement.

The included Statement of Ownership shall be completed and attached to the proposal. This requirement applies to all forms of business organizations, including, but not limited to, corporations and partnerships, publicly-owned corporations, limited partnerships, limited liability corporations, limited liability partnerships, sole proprietorship, and Subchapter S corporations. Failure to submit a disclosure document shall result in rejection of the proposal as it cannot be remedied after proposals have been opened.

Not-for-profit entities should fill in their name, check the not-for-profit box, and certify the form. No other information is necessary.

Non-Collusion Affidavit

The Non-Collusion Affidavit, which is part of these specifications, shall be properly executed and submitted with the bid proposal.

State of New Jersey Business Registration Certificate

Pursuant to N.J.S.A. 52:32-44, a Contracting Agency is prohibited from entering into a contract with an entity unless the bidder/proposer/contractor, and each subcontractor that is required by law to be named in a bid/proposal/contract has a valid Business Registration Certificate on file with the Division of Revenue and Enterprise Services within the Department of the Treasury.

Prior to contract award or authorization, the contractor shall provide the Contracting Agency with its proof of business registration and that of any named subcontractor(s).

Subcontractors named in a bid or other proposal shall provide proof of business registration to the bidder, who in turn, shall provide it to the Contracting Agency prior to the time a contract, purchase order, or other contracting document is awarded or authorized.

During the course of the contract performance:

1. The contractor shall not enter into a contract with a subcontractor unless the subcontractor first provides the contractor with a valid proof of business registration.
2. The contractor shall maintain and submit to the Contracting Agency a list of subcontractors and their addresses that may be updated from time to time.
3. The contractor and any subcontractor providing goods or performing services under the contract, and each of their affiliates, shall collect and remit to the Director of the Division of Taxation in the Department of the Treasury, the use tax due pursuant to the Sales and Use Tax Act, (N.J.S.A. 54:32B-1 et seq.) on all sales of tangible personal property delivered into the State. Any questions in this regard can be directed to the Division of Taxation at (609) 292-6400. Form NJ-REG can be filed online at <http://www.state.nj.us/treasury/revenue/busregcert.shtml>.

Before final payment is made under the contract, the contractor shall submit to the Contracting Agency a complete and accurate list of all subcontractors used and their addresses.

Pursuant to N.J.S.A. 54:49-4.1, a business organization that fails to provide a copy of a business registration as required, or that provides false business registration information, shall be liable for a penalty of \$25.00 for each day of violation, not to exceed \$50,000.00, for each proof of business registration not properly provided under a contract with a contracting agency.

Emergency Purchases or Contracts – For purchases of an emergent nature, the contactor shall provide its Business Registration Certificate within two weeks from the date of purchase or execution of the contract or prior to payment for goods or services, whichever is earlier.

The requirement that a contractor provide proof of business registration or providing the contracting agency with sufficient information for the contracting agency to verify proof of registration of the contractor or named subcontractors must be submitted to the Purchasing Department by 12:00 Noon on the third Wednesday of each month. Failure to comply with this request will result in the rejection of your bid or request for proposal.

W-9, Request for Taxpayer Identification Number and Certification

The W-9, Request for Taxpayer Identification Number and Certification, is requested by the Montgomery Township Board of Education.

Political Contribution Disclosure (Pay-to Play)

In accordance with c. 271, L. 2005, the Montgomery Township Board of Education will require from all business entities submitting proposals, or with whom the Board is negotiating or considering an appointment, a list of political contributions (as defined below) made by the entity (including certain company officials and their spouses) during the preceding 12-month period, along with the date and amount of each contribution and the name of the recipient of each contribution. This requirement will be strictly enforced with respect to all covered contracts, including appointments at the annual reorganization meeting of the Board. The list must accompany your proposal or must be provided no later than ten (10) days prior to the Board's approval of the contract.

This requirement applies to individuals as well as to any form of business entity. The only exceptions are for the following:

1. Contracts having an anticipated value of \$17,500.00 or less are exempted; and
2. Emergency contracts are exempted.

It is your responsibility to prepare and file the list of political contributions and to make certain that the list complies with the law. Your failure to do so will preclude consideration of your appointment or contract for services. Please be advised that the political contributions list you submit to the Montgomery Township Board of Education must include all contributions made to any State, county or municipal committee of any political party; to any legislative leadership committee; to any candidate committee of a candidate for, or holder of, an elective office of this Board of Education and of any other public entity located in Somerset County or located in the 16th Legislative District.

You are obligated to file an annual disclosure statement on political contributions with the New Jersey Election Enforcement Commission if you receive contracts in excess of \$50,000.00 from public entities in a calendar year. Business entities are responsible for determining if filing is necessary. Additional information on this requirement is available from ELEC at 888-313-3532 or at www.elec.state.nj.us.

Disclosure of Investment Activities in Iran

Pursuant to Public Law 2012, c. 25, any person or entity that submits a bid or proposal or otherwise proposes to enter into or renew a contract must complete the certification enclosed in the bid to attest, under penalty of perjury, that the person or entity, or one of the person or entity's parents, subsidiaries, or affiliates, is not identified on a list created and maintained by the Department of the Treasury as a person or entity engaging in investment activities in Iran. If the District finds a person or entity to be in violation of the principles which are the subject of this law, they shall take action as may be appropriate and provided by law, rule or contract, including but not limited to, imposing sanctions, seeking compliance, recovering damages, declaring the party in default and seeking debarment or suspension of the person or entity.

Public Works Contractor Registration Certificate

N.J.S.A. 34:11-56.48 et seq. requires that a general or prime contractor and any listed subcontractors named in the contractor's bid proposal shall possess a certificate at the time the bid proposal is submitted. After bid proposals are received and prior to award of contract, the successful contractor shall submit a copy of the contractor's certification along with those of all listed subcontractors. All non-listed subcontractors and lower tier sub-subcontractors shall be registered prior to starting work on the project. It is the general contractor's responsibility that all non-listed sub-contractors at any tier have their certificate prior to starting work on the job.

Under the law a "contractor" is "a person, partnership, association, joint stock company, trust, corporation or other legal business entity or successor thereof who enters into a contract" which is subject to the provisions of the New Jersey Prevailing Wage Act [N.J.S.A. 34:11-56.25, et seq.] It applies to contractors based in New Jersey or in another state.

The law defines "public works projects" as contracts for "public work" as defined in the Prevailing Wage statute [N.J.S.A. 34:11-56.26(5)]. The term means:

- "Construction, reconstruction, demolition, alteration, or repair work, or maintenance work, including painting and decorating, done under contract and paid for in whole or in part out of the funds of a public body, except work performed under a rehabilitation program.
- "Public work" shall also mean construction, reconstruction, demolition, alteration, or repair work, done on any property or premises, whether or not the work is paid for from public funds..."
- "Maintenance work" means the repair of existing facilities when the size, type or extent of such facilities is not thereby changed or increased. While "maintenance" includes painting and decorating and is covered under the law, it does not include work such as routine landscape maintenance or janitorial services.

To register, a contractor must provide the State Department of Labor with a full and accurately completed application form. The form is available online at www.state.nj.us/labor/lsse/lspubcon.html. N.J.S.A. 34:11-56.55 specifically prohibits accepting applications for registration as a substitute for a certificate of registration. If copies of the Public Works Contractor Registration Certificate are available for the general or prime contractor and any listed subcontractors named in the proposal, please attach a copy to your bid document.

Qualifications of Bidders

If the bid exceeds \$20,000.00 the State of New Jersey, Department of the Treasury, Division of Property Management and Construction must prequalify all contractors prior to the date bids are received in accordance with N.J.S.A.18A:18A-26. Each contractor under the terms of this New Jersey statute must submit a valid or active "Notice of Classification" and "Total Amount of Uncompleted Contracts". In addition, each contractor must furnish with their bid the names and proof of prequalification of all subcontractors by submitting the same documents described above. Failure to submit these documents with your bid will render the bid as being non-responsive to the bid requirements and will be rejected.

New Jersey State Prevailing Wage Act and Regulations

Pursuant to N.J.S.A. 34:11-56.25 et seq., contractors on projects for public work shall adhere to all requirements of the New Jersey Prevailing Wage Act. The contractor shall be required to submit a certified payroll record to the owner within ten (10) days of the payment of the wages. In the event it is found that any worker, employed by the contractor or any subcontractor has been paid a rate of wages less than the prevailing wage required to be paid, the owner may terminate the contractor's or subcontractor's right to proceed with the work, or such part of the work as to which there has been a failure to pay required wages and prosecute the work to completion.

The contractor is also responsible for obtaining and submitting all subcontractors' certified payroll records within the aforementioned time period. The contractor shall submit said certified payrolls in the form set forth

in N.J.A.C. 12:606.1(c). It is the contractor's responsibility to obtain any additional copies of the certified payroll form to be submitted by contacting the New Jersey Department of Labor and Workforce Development, Division of Workplace Standards. Additional information is available at http://lwd.dol.state.nj.us/labor/wagehour/wagerate/pwr_construction.html.

Federal Non-Debarment Certification

Pursuant to state law any natural person, company, firm, association, corporation, or other entity prohibited, or “debarred,” from contracting with the federal government agencies, shall also be prohibited from contracting for public work in the state of New Jersey. This prohibition also extends to any affiliate organization(s) held by or subject to the control of an entity of that prohibited person or entity. (N.J.S.A. 52:32-44.1/P.L. 2019, c.406)

Prior to awarding a contract for public work a local unit must obtain written certification from the contracting person or entity through the form below, attesting to their non-debarment from contracting with federal government agencies. Contracting units are reminded that they must fill-in the boilerplate information in the certification sections of Parts II through IV regarding their name and type of contracting unit before using the form.

Prompt Payment for Construction Related Contracts, Professional or Skilled Services

When the contractor has performed in accordance with the provisions of the contract and the invoice (bill) including a properly prepared, dated and signed voucher for the work has been approved and certified by the board of education or the board’s authorized approving agent, the board shall pay the amount due to the contractor for each payment not more than 30 days after the date received, which has been established as the 22nd of each month. The invoice shall be deemed approved and certified 20 days after the board or the board’s authorized approving agent receives it unless the board or the board’s authorized approving agent, before the 20-day period, informs the contractor in a written statement of the amount withheld and the amount to be paid, the reason for withholding the payment and how the deficiency can be cured.

In order to have your invoice (bill) processed for payment, you must submit your properly prepared, dated and signed voucher, along with any additionally required paperwork including, but not limited to, Payroll Certification for Public Works Projects, Monthly Project Workforce Report-Construction (AA-202), etc. to the Accounts Payable Department. Invoices (bills) with a properly prepared, dated and signed voucher will be approved for payment by the board at the first public meeting after the 20th day. After the board approves payment of invoices (bills) with properly prepared, dated and signed voucher, payment will be released the day after the public meeting. All payments will be mailed unless other arrangements have been made with our Accounts Payable Department. In the event that Alternate Dispute Resolution is needed, mediation is the method that shall be used.

The board has established the billing date as the 22nd of each month except when the 22nd falls on a weekend.

| Bill Date | Public Meeting Date (If a complete invoice with voucher.) | Payment Cycle (Checks mailed) |
|--------------------|----------------------------------------------------------------------|------------------------------------------|
| January 22, 2021 | February 23, 2021 | February 24, 2021 |
| February 22, 2021 | March 16, 2021 | March 17, 2021 |
| March 22, 2021 | April 27, 2021 | April 28, 2021 |
| April 22, 2021 | May 25, 2021 | May 26, 2021 |
| May 21, 2021 | June 22, 2021 | June 23, 2021 |
| June 22, 2021 | July 13, 2021 | July 14, 2021 |
| July 22, 2021 | August 24, 2021 | August 25, 2021 |
| August 23, 2021 | September 28, 2021 | September 29, 2021 |
| September 22, 2021 | October 26, 2021 | October 27, 2021 |
| October 22, 2021 | November 23, 2021 | November 24, 2021 |
| November 22, 2021 | December 14, 2021 | December 15, 2021 |

Please note; that a new billing schedule for the year 2022 will be established after the January 4, 2022, Re-Organization Meeting.

Federal Clean Air Act

The contractor providing service shall, in all aspects, comply with the Federal Clean Air Act. This is to say that the contractor's service personnel are to be thoroughly and properly trained, equipped, and keep all proper records for compliance with the Act. The contractor shall take all necessary steps to insure that all work done for the Board of Education is done in compliance with the Federal Clean Air Act. The service companies shall furnish to the Board of Education copies of all training and service as well as other necessary documentation as proof of compliance with the law if applicable.

The New Jersey Worker and Community Right to Know Act

The manufacturer or supplier of chemical substances or mixtures shall label them in accordance with the N.J. Worker and Community Right to Know Law (N.J.S.A. 34:5A-1 et seq., and N.J.A.C 8:59-1.1 et seq.). All direct use containers shall bear a label indicating the chemical name(s) and Chemical Abstracts Service number(s) of all hazardous substances in the container, and all other substances which are among the five most predominant substances in the container, or their trade secret registry number(s) pursuant to N.J.A.C. 8:59-5. "Container" means a receptacle used to hold a liquid, solid or gaseous substance such as bottles, bags, barrels, cans, cylinders, drums and cartons. (N.J.A.C. 8:59-1.3). Further, all applicable Material Safety Data Sheets (MSDS) - hazardous substance fact sheet - must be furnished. All containers which are stored at an owner's facilities by the contractor or subcontractors shall display RTK labeling. Vendors with questions concerning labeling should contact the New Jersey Department of Health and Senior Services Right to Know Program for assistance in developing proper labels. www.nj.gov/health/workplacehealthandsafety/right-to-know/

One copy of the Material Safety Data Sheets (MSDS) must be submitted with your proposal for each chemical substance or mixture requested. Material Safety Data Sheets (MSDS) sheets must be sent with the delivery and two copies of the same sheets must be sent to Mr. Michael O'Neil, Montgomery Township Board of Education, 1014 Route 601, Skillman, New Jersey 08558.

Harassment, Intimidation and Bullying ("Anti-Bullying Bill of Rights Act")

Pursuant to P.L. 2010, c.122, all contracted service providers, defined as any organization that is a party to a contract or agreement for services with the Board, and all employees of contracted service providers are required to comply with the provisions of the District's anti-bullying policy. Contracted service providers and their employees shall verbally report any act of harassment, intimidation or bullying of a student on the same day on which the act was witnessed, or on the same day on which reliable information that a student has been subject to harassment, intimidation or bullying was received, and shall report the same in writing within two (2) school days. All verbal and written reports of harassment, intimidation or bullying of a student shall be made to the school principal or to any school administrator or safe schools resource officer.

Reports may be made anonymously in accordance with the reporting procedure as set forth in the anti-bullying policy. The District shall provide to all contracted service providers and their employees a copy of the District's anti-bullying policy and information regarding the policy.

Multiyear Contracts

The Montgomery Township Board of Education has the option to enter into a multiyear contract. The statutory length of which a contract is three years or less may include provisions for no more than one two-year or two one-year extensions. Any price change included, as part of an extension shall not exceed the change in the index rate for the twelve (12) months preceding the most recent quarterly calculation available at the time the contract is renewed. No contract shall be extended so that it runs for more than a total of five (5) consecutive years (N.J.S.A.18A:18A-42),

Special Instructions

No work shall be performed without a signed authorized hard copy purchase order. The contractor shall set up a mutually agreeable time with the Montgomery Township Board of Education's representative as to when work is to be performed. The contractor must sign-in at the main office of each building in which the work is to be completed. The contractor will be issued a visitors pass that must be worn in clear sight at all times during occupancy in the pertaining school. Upon completion of work the contractor shall have the job sheet of work performed signed off by the Director of Facilities, building principal or head custodian.

The contractor shall provide with each invoice a complete breakdown of all parts and labor by building along with the approved job sheet. All labor will be compared against the sign-in and out sheet for confirmation of payment. Failure of the contractor to have the work approved will impede payment for services rendered. The Board of Education is exempt from all local, state or federal sales, use or excise tax.

Refer to New Jersey Department of Labor, Prevailing Wage Rate Determination for Somerset County. Prevailing wages must be paid for individual projects over \$2,000.00. Certified payrolls will be required with the invoices for those projects.

The successful contractor will be responsible for the entire project. In the event that **the contractor** subcontracts out any portion of this project **the contractor** will be the responsible contact of the Montgomery Township Board of Education.

If applicable, the contractor shall obtain all necessary permits that are required to perform the work. The contractor shall also pay any and all permit fees that cannot be waived by the Montgomery Township Board of Education. The contractor shall advise the Montgomery Township Board of Education of the necessary permits that are needed so a waiver can be requested in ample time before the start of the project. The contractor shall set-up all required inspections with the proper governing officials prior, during and upon completion of the work and provide a Certification of Inspection to the Montgomery Board of Education.

The contractor shall provide all materials, equipment and labor that are necessary for the completion of the project. All the materials used shall be as environmentally safe as is technologically possible. The application practices used are to be as per all manufactures requirements. The contractor shall follow all applicable laws and regulations concerning the safe application of all materials used in the performance of the job.

Any and all asbestos containing materials that may be near the work area are to be avoided and shall be left undisturbed. All employees of the contractor must have Asbestos Awareness Training. The contractor is to provide documentation of training with their quotation.

The contractor shall take all necessary precautions during the project to effectually protect all parties from injury and property damage, and shall be liable for such damage or injury until the project is fully completed, approved, and accepted by the owner.

All work shall be performed in a neat and workmanlike manner. The contractor is to perform all necessary touch-ups that may be needed. The work area shall be kept orderly and in a clean and neat condition during each workday and at completion of the project. The contractor shall, as necessary, make provision for a safe work area for all building occupants and visitors.

The contractor shall be responsible for the removal and proper disposal of all excess materials, trash and/or debris generated from this project according to all-existing disposal laws and regulations. When possible the material should be recycled when permitted by law. If a dumpster is required for disposal, the contractor shall check with the building management representative for approval of its placement.

Contractor personnel are to follow all district health and safety policies and shall refrain from smoking on district property.

Please submit the following:

1. All hourly labor rates including after hours, weekends and holidays. The Montgomery Township Board of Education will not pay Travel Time. If a contractor wants to impose Travel Time charges they must be incorporated into the hourly labor rates.
2. All discount off list or part mark-up percentages.
3. Response time in the event of an emergency is **4 Hours** from initial contact
4. Any other pertinent costs that would be submitted in the event that the contractor was called in to perform work.
5. All hourly labor rates and discount off list/parts percentage costs shall hold for entire school year for which proposals are solicited - school year beings July 1 present year - June 30 of following year unless otherwise noted.

This Time and Material contract ***does not preclude*** the owner from seeking competitive bids or quotes on specific projects similar to the trades in this document. The owner has the option of requesting “Not to Exceed” quotation for work under this contract. Estimates are to be provided as a service to the owner and prepared at no additional cost to the owner.

NOTE: If the contractor is unable to respond to that call within a reasonable amount of time a secondary contractor may be called.

Checklist

As a courtesy, the Board has prepared this reminder checklist for items pertaining to this bid. The checklist is not considered to be all-inclusive. Bidders are to read and become familiar with all instructions outlined in the bid package.

- _____ Affirmative Action Language – Exhibit A
- _____ Bid Security/Guarantee; Bid Bond, Cashier’s Check or Certified Check
- _____ Consent of Surety
- _____ Statement of Ownership Disclosure
- _____ Non-Collusion Affidavit
- _____ State of New Jersey Business Registration Certificate
- _____ W-9, Request for Taxpayer Identification Number and Certification
- _____ Political Contribution Disclosure Form (Pay-to-Play)
- _____ Disclosure of Investment Activities in Iran
- _____ Public Works Contractor Registration Act
- _____ Notice of Classification from State of New Jersey, Department of Treasury,
Department of Property Management and Construction (if applicable)
- _____ Total Amount of Uncompleted Contracts – DBC 701 (if applicable)
- _____ Federal Non-Debarment Certification
- _____ List of Subcontractors
- _____ Project References
- _____ Example of Certificate of Insurance
- _____ Acknowledgment of Receipt of Addenda
- _____ Proposal Form

EXHIBIT A
MANDATORY EQUAL EMPLOYMENT OPPORTUNITY LANGUAGE
N.J.S.A. 10:5-31 et seq. (P.L.1975, c.127) N.J.A.C. 17:27 et seq.
GOODS, GENERAL SERVICES, AND PROFESSIONAL SERVICES CONTRACTS

During the performance of this contract, the contractor agrees as follows:

The contractor or subcontractor, where applicable, will not discriminate against any employee or applicant for employment because of age, race, creed, color, national origin, ancestry, marital status, affectional or sexual orientation, gender identity or expression, disability, nationality or sex. Except with respect to affectional or sexual orientation and gender identity or expression, the contractor will ensure that equal employment opportunity is afforded to such applicants in recruitment and employment, and that employees are treated during employment, without regard to their age, race, creed, color, national origin, ancestry, marital status, affection-al or sexual orientation, gender identity or expression, disability, nationality or sex. Such equal employment opportunity shall include, but not be limited to the following: employment, up-grading, demotion, or transfer; recruitment or recruitment advertising; layoff or termination; rates of pay or other forms of compensation; and selection for training, including apprentice-ship. The contractor agrees to post in conspicuous places, available to employees and applicants for employment, notices to be provided by the Public Agency Compliance Officer setting forth provisions of this nondiscrimination clause.

The contractor or subcontractor, where applicable will, in all solicitations or advertisements for employees placed by or on behalf of the contractor, state that all qualified applicants will receive consideration for employment without regard to age, race, creed, color, national origin, ancestry, marital status, affectional or sexual orientation, gender identity or expression, disability, nationality or sex.

The contractor or subcontractor will send to each labor union, with which it has a collective bargaining agreement, a notice, to be provided by the agency contracting officer, advising the labor union of the contractor's commitments under this chapter and shall post copies of the notice in conspicuous places available to employees and applicants for employment.

The contractor or subcontractor, where applicable, agrees to comply with any regulations promulgated by the Treasurer pursuant to N.J.S.A. 10:5-31 et seq., as amended and supplemented from time to time and the Americans with Disabilities Act.

The contractor or subcontractor agrees to make good faith efforts to meet targeted county employment goals established in accordance with N.J.A.C. 17:27-5.2.

The contractor or subcontractor agrees to inform in writing its appropriate recruitment agencies including, but not limited to, employment agencies, placement bureaus, colleges, universities, and labor unions, that it does not discriminate on the basis of age, race, creed, col-or, national origin, ancestry, marital status, affectional or sexual orientation, gender identity or expression, disability, nationality or sex, and that it will discontinue the use of any recruitment agency which engages in direct or indirect discriminatory practices.

The contractor or subcontractor agrees to revise any of its testing procedures, if necessary, to assure that all personnel testing conforms with the principles of job related testing, as established by the statutes and court decisions of the State of New Jersey and as established by applicable Federal law and applicable Federal court decisions.

In conforming with the targeted employment goals, the contractor or subcontractor agrees to review all procedures relating to transfer, upgrading, downgrading and layoff to ensure that all such actions are taken without regard to age, race, creed, color, national origin, ancestry, marital status, affectional or sexual orientation, gender identity or expression, disability, nationality or sex, consistent with the statutes and court decisions of the State of New Jersey, and applicable Federal law and applicable Federal court decisions.

The contractor shall submit to the public agency, after notification of award but prior to execution of a goods and services contract, one of the following three documents:

- Letter of Federal Affirmative Action Plan Approval;
- Certificate of Employee Information Report; or
- Employee Information Report Form AA-302 (electronically provided by the Division and distributed to the public agency through the Division’s website at: http://www.state.nj.us/treasury/contract_compliance/).

The contractor and its subcontractors shall furnish such reports or other documents to the Division of Purchase & Property, CCAU, EEO Monitoring Program as may be requested by the office from time to time in order to carry out the purposes of these regulations, and public agencies shall furnish such information as may be requested by the Division of Purchase & Property, CCAU, EEO Monitoring Program for conducting a compliance investigation pursuant to N.J.A.C. 17:27-1.1 et seq.

This form is a summary of the successful contractor’s requirement to comply with the requirements of N.J.S.A. 10:5-31 and N.J.A.C. 17:27 et seq.

The successful contractor shall submit to the public agency, the EEO/AA evidence with your proposal or after notification of award but prior to execution of goods, professional services and general services contract, one of the following three documents as forms of evidence:

- (a) A Letter of Federal Approval indicating that the contractor is under an existing federally approved or sanctioned affirmative action program. A copy of the approval letter must be provided by the contractor to the Public Agency and the Division. This approval letter is valid for one year from the date of issuance. Or,

_____ Yes _____ No

- (b) A Certificate of Employee Information Report, issued in accordance with N.J.A.C. 17:27 et seq. The contractor must provide a copy of the Certificate to the Public Agency as evidence of its compliance with the regulations. The Certificate represents the review and approval of the contractor’s Employee Information Report, Form AA-302 by the Division. Or,

_____ Yes _____ No

- (c) The successful contractor shall complete an Initial Employee Report, Form AA-302, submit it to the Division and forward a copy of the form to the Public Agency.

_____ Yes _____ No

If you answered **NO** to the questions above, Form AA-302 can be electronically provided by the Division and distributed to the public agency through the Divisions website: www.state.nj.us/treasury/contract_compliance along with the required check in the amount of \$150.00 payable to The Treasurer, State of New Jersey, this fee in non-refundable. Upon submission and review by the Division, the Report shall constitute evidence of compliance with the regulations.

The undersigned vendor certifies that he/she is aware of the commitment to comply with the requirements of N.J.S.A. 10:5-31 and N.J.A.C. 17:27 et seq. and agrees to furnish the required forms of evidence. The undersigned contractor further understands that his/her proposal shall be rejected as non-responsive if said contractor fails to comply with the requirements of N.J.S.A. 10:5-31 and N.J.A.C. 17:27. et seq.

Company Name _____

Name _____

(Print)

Signature _____

Title _____

Date _____

If your Letter of Federal Affirmative Action Plan Approval or your State of New Jersey Certificate of Employee Information Report is available, please attach to this document.

**Americans with Disabilities Act of 1990
Equal Opportunity for Individuals with Disability**

The CONTRACTOR and the OWNER do hereby agree that the provisions of Title II of the Americans With Disabilities Act of 1990 (the "ACT") (42 U.S.C. S12101 et seq.), which prohibits discrimination on the basis of disability by public entities in all services, programs, and activities provided or made available by public entities, and the rules and regulations promulgated pursuant there unto, are made a part of this contract. In providing any aid, benefit, or service on behalf of the OWNER pursuant to this contract, the CONTRACTOR agrees that the performance shall be in strict compliance with the Act. In event that the Contractor, its agents, servants, employees, or subcontractors violate or are alleged to have violated the Act during the performance of this contract, the CONTRACTOR shall defend the OWNER in any action or administrative proceeding commenced pursuant to this Act. The Contractor shall indemnify, protect, and save harmless the OWNER, its agents, servants, and employees from and against any and all suits, claims, losses, demands, or damages, of whatever kind or nature arising out of or claimed to arise out of alleged violation. The CONTRACTOR shall, at its own expense, appear, defend, and pay any and all charges for legal services and any and all costs and other expenses arising from such action or administrative proceeding or incurred in connection therewith. In any and all complaints brought pursuant to the OWNER grievance procedure, the CONTRACTOR agrees to abide by any decision of the OWNER, which is rendered pursuant to, said grievance procedure. If any action or administrative proceeding results in an award of damages against the OWNER or if the OWNER incurs any expense to cure a violation of the ADA which has been brought pursuant to its grievance procedure, the CONTRACTOR shall satisfy and discharge the same at its own expense.

The OWNER shall, as soon as practicable after a claim has been made against it, give written notice thereof to the CONTRACTOR along with full and complete particulars of the claim. If any action or administrative proceedings is brought against the OWNER or any of its agents, servants, and employees, the OWNER shall expeditiously forward or have forwarded to the CONTRACTOR every demand, complaint, notice, summons, pleading, or other process received by the OWNER or its representatives.

It is expressly agreed and understood that any approval by the OWNER of the services provided by the CONTRACTOR pursuant to this contract will not relieve the CONTRACTOR of the obligation to comply with the Act and to defend, indemnify, protect, and save harmless the OWNER pursuant to this paragraph.

It is further agreed and understood that the OWNER assumes no obligation to indemnify or save harmless the CONTRACTOR, its agents, servants, employees, and subcontractors for any claim which may arise out of their performance of this Agreement. Furthermore, the CONTRACTOR expressly understands and agrees that the provisions of this indemnification clause shall in no way limit the CONTRACTOR'S obligations assumed in this Agreement, nor shall they be construed to relieve the CONTRACTOR from any liability, nor preclude the OWNER from taking any other actions available to it under any other provisions of the Agreement or otherwise a law.

New Jersey Anti-Discrimination Provisions
N.J.S.A. 10:2-1 ET SEQ.

Pursuant to N.J.S.A. 10:2-1, if awarded a contract, the contractor agrees that:

- a. In the hiring of persons for the performance of work under this contract or any subcontract hereunder, or for the procurement, manufacture, assembling or furnishing of any such materials, equipment, supplies or services to be acquired under this contract, no contractor, nor any person acting on behalf of such contractor or subcontractor, shall, by reason of race, creed, color, national origin, ancestry, marital status, gender identity or expression, affectional or sexual orientation or sex, discriminate against any person who is qualified and available to perform the work to which the employment relates:
- b. No contractor, subcontractor, nor any person on his behalf shall in any manner, discriminate against or intimidate any employee engaged in the performance of work under this contract or any subcontract hereunder, or engaged in the procurement, manufacture, assembling or furnishing of any such materials, equipment, supplies or services to be acquired under such contract, on account of race, creed, color national origin, ancestry, marital status, gender identity or expression, affectional or sexual orientation or sex;
- c. There may be deducted from the amount payable to the contractor by the contracting public agency, under this contract, a penalty of \$50.00 for each person for each calendar day during which such person is discriminated against or intimidated in violation of the provisions of the contract; and
- d. This contract may be canceled or terminated by the contracting public agency, and all money due or to become due hereunder may be forfeited, for any violation of this section of the contract occurring after notice to the contractor from the contracting public agency of any prior violation of this section of the contract.

No provision in this section shall be construed to prevent a Board of Education designating that a contract, subcontract or other means of procurement of goods, services, equipment or construction shall be awarded to a small business enterprise, minority business enterprise or a women's business enterprise pursuant to P.L. 1985, c.490 (C.18A:18A-51 et seq.).

BID BOND

KNOW ALL MEN BY THESE PRESENTS, that we, the undersigned, _____

as Principal, _____ and as Surety, is _____ hereby held

and firmly bound unto _____ as Owner, in the Penal Sum of (\$ _____) for the payment of which, well and truly to be made, we hereby jointly and severally bind ourselves, successors and assigns.

Signed this ____ day of _____ 20____

The condition of the above obligation is such that whereas the Principal has submitted to a certain bid, attached hereto and hereby made a part of hereof, to enter into a contract in writing for the

NOW THEREFORE,

- A. If said bid shall be rejected or in the alternative,
- B. If said bid shall be accepted and the Principal shall execute and deliver a contract properly completed in accordance with said bid and shall furnish a bond for his faithful performance of said contract, and for the payment of all persons performing labor or furnishing materials in the connection therewith, and shall in all other respects perform the agreement created by the acceptance of said bid,

Then this obligation shall be void, otherwise the same shall remain in full force and effect; it being expressly understood and agreed that the liability of the surety for any and all claims hereunder shall, in no event, exceed the penal amount of this obligation as herein stated.

The Surety, for value received, hereby stipulates and agrees that the obligations of said Surety and its bond shall be in no way impaired or affected by any extension of the time within which the Owner may accept such bid; and Surety does hereby waive notice of any such extension.

IN WITNESS WHEREOF, the Principal and the Surety have hereunto set their hands and seals, and such of them as are corporations have caused their corporate seals to be hereto affixed and these presents to be signed by their proper officers, the day and year first set forth above.

BY: _____
Witness

Principal

BY: _____
Witness

Surety

Attorney-in-Fact

CONSENT OF SURETY

A performance bond will be required from the successful contractor on this project, and consequently, all bidders shall submit, with their bid, a consent of surety in substantially the following form:

To: _____
(Owner)

Re: _____
(Contractor)

(Project Description)

This is to certify that the _____
(Surety Company)

will provide to _____ a performance bond in
(Owner)

the full amount of awarded contract in the event that said contractor is awarded a contract for the above project.

(CONTRACTOR)

(Authorized Agent of Surety Company)

Date: _____

**CONSENT OF SURETY MUST BE SIGNED BY AN AUTHORIZED AGENT
OR REPRESENTATIVE OF A SURETY COMPANY AUTHORIZED TO DO BUSINESS
IN NEW JERSEY AND NOT BY
THE INDIVIDUAL OR COMPANY REPRESENTATIVE SUBMITTING THE BID.**

STATEMENT OF OWNERSHIP DISCLOSURE

N.J.S.A. 52:25-24.2 (P.L. 1977, c.33, as amended by P.L. 2016, c.43)

This statement shall be completed, certified to, and included with all bid and proposal submissions. Failure to submit the required information is cause for automatic rejection of the bid or proposal.

Name of Business: _____

Address of Business: _____

Part I

Check the box that represents the type of business organization:

- Sole Proprietorship (skip Parts II and III, execute certification in Part IV)
- Non-Profit Corporation (skip Parts II and III, execute certification in Part IV)
- For-profit Corporation (any type) Limited Liability Company (LLC)
- Partnership Limited Partnership Limited Liability Partnership (LLP)
- Other (be specific): _____

Part II

The list below contains the names and addresses of all stockholders in the corporation who own 10% or more of its stock, of any class, or of all individual partners in the partnership who own a 10% or greater interest therein, or of all members in the limited liability company who own a 10% or greater interest therein, as the case may be. **(Complete the list below in this section.)**

OR

No one stockholder in the corporation owns 10% or more of its stock, of any class, or no individual partner in the partnership owns a 10% or greater interest therein, or that no member in the limited liability company owns a 10% or greater interest therein, as the case may be. **(Skip to Part IV)**

| Name of Individual or Business Entity | Home Address (for Individuals) or Business Address |
|---------------------------------------|----------------------------------------------------|
| | |
| | |
| | |
| | |

(Please attach additional sheets if more space is needed.)

Part III

Disclosure of 10% or greater ownership in the Stockholders, Partners or LLC members listed in Part II

If a bidder has a direct or indirect parent entity which is publicly traded, and any person holds a 10% or greater beneficial interest in the publicly traded parent entity as of the last annual federal Security and Exchange Commission (SEC) or foreign equivalent filing, ownership disclosure can be met by providing links to the website(s) containing the last annual filing(s) with the federal Securities and Exchange Commission (or foreign equivalent) that contain the name and address of each person holding a 10% or greater beneficial interest in the publicly traded parent entity, along with the relevant page numbers of the filing(s) that contain the information on each such person.

| Website (URL) containing the last annual SEC (or foreign equivalent filing | Pages #'s |
|----------------------------------------------------------------------------|-----------|
| | |
| | |
| | |
| | |

(Please attach additional sheets if more space is needed.)

Please list the names and addresses of each stockholder, partner or member owning a 10 % or greater interest in any corresponding corporation, partnership and/or limited liability company (LLC) listed in Part II **other than for any publicly traded parent entities referenced above.** The disclosure shall be continued until names and addresses of every noncorporate stockholder, and individual partner, and member exceeding the 10 % ownership criteria established pursuant to N.J.S.A. 52:25-24.2 has been listed.

| Stockholder/Partner/Member and Corresponding Entity Listed in Part II | Home Address (for Individuals) or Business Address |
|-----------------------------------------------------------------------|----------------------------------------------------|
| | |
| | |
| | |
| | |
| | |

(Please attach additional sheets if more space is needed.)

Part IV

Certification

I, being duly sworn upon my oath, hereby represent that the foregoing information and any attachments thereto to the best of my knowledge are true and complete. I acknowledge: that I am authorized to execute this certification on behalf of the bidder/proposer; that the Montgomery Township Board of Education is relying on the information contained herein and that I am under a continuing obligation from the date of this certification through the completion of any contracts with school district to notify the school district in writing of any changes to the information contained herein; that I am aware that it is a criminal offense to make a false statement or misrepresentation in this certification, and if I do so, I am subject to criminal prosecution under the law and that it will constitute a material breach of my agreement(s) with the, permitting the school district to declare any contract(s) resulting from this certification void and unenforceable.

| | | | |
|---------------------------|--|---------------|--|
| Full Name (Print): | | Title: | |
| Signature: | | Date: | |

Non-Collusion Affidavit
N.J.S.A. 52:34-15

I, _____ residing in _____
(name of affiant) (name of city, town or municipality)

in the County of _____ and State of _____ being
of full age and duly sworn according to law, on my oath depose and say that:

I am _____ of the firm of _____
(title or position) (name of firm)

_____ the bidder making this Proposal for the bid entitled

_____ and that I executed the said proposal with
(title of bid proposal)

full authority to do so. Further, the bidder has not, directly or indirectly entered into any agreement, participated in any collusion, or otherwise taken any action in restraint of free, competitive bidding in connection with the above named project. All statements contained in said proposal and in this affidavit are true and correct, and made with full knowledge that the State of New Jersey and the Montgomery Township Board or Education relies upon the truth of the statements contained in said Proposal and in the statements contained in this affidavit in awarding the contract for the said project.

I further warrant that no person or selling agency has been employed or retained to solicit or secure such contract upon an agreement or understanding for a commission, percentage, brokerage, or contingent fee, except bona fide employees or bona fide established commercial or selling agencies maintained by

(name of contractor)

Subscribed and sworn to

before me this _____ day

of _____, 2_____

Signature

(Type or print name of affiant under

signature)

Notary public of

My Commission expires _____

(Seal)

Request for Taxpayer Identification Number and Certification

**Give Form to the
requester. Do not
send to the IRS.**

▶ Go to www.irs.gov/FormW9 for instructions and the latest information.

| | | |
|--------------------------------------------------------|--------------------------------------------------------------------------------------------------------------------------------------------------------------------------------------------------------------------------------------------------------------------------------------------------------------------------------------------------------------------------------------------------------------------------------------------------------------------------------------------------------------------------------------------------------------------------------------------------------------------------------------------------------------------------------------------------------------------------------------------------------------------------------------------------------------------------------------------------------------------------------------------------------------------------------------------------------------------------------------------------------------------------------------------------------------------------------------------------------------------------------------------------|-------------------------------------------------------------------------------------------------------------------------------------------------------------------------------------------------------------------------------------------------------------------------------------------|
| Print or type. See Specific Instructions on page 3. | <p>1 Name (as shown on your income tax return). Name is required on this line; do not leave this line blank.</p> | |
| | <p>2 Business name/disregarded entity name, if different from above</p> | |
| | <p>3 Check appropriate box for federal tax classification of the person whose name is entered on line 1. Check only one of the following seven boxes.</p> <p><input type="checkbox"/> Individual/sole proprietor or single-member LLC</p> <p><input type="checkbox"/> C Corporation</p> <p><input type="checkbox"/> S Corporation</p> <p><input type="checkbox"/> Partnership</p> <p><input type="checkbox"/> Trust/estate</p> <p><input type="checkbox"/> Limited liability company. Enter the tax classification (C=C corporation, S=S corporation, P=Partnership) ▶ _____</p> <p>Note: Check the appropriate box in the line above for the tax classification of the single-member owner. Do not check LLC if the LLC is classified as a single-member LLC that is disregarded from the owner unless the owner of the LLC is another LLC that is not disregarded from the owner for U.S. federal tax purposes. Otherwise, a single-member LLC that is disregarded from the owner should check the appropriate box for the tax classification of its owner.</p> <p><input type="checkbox"/> Other (see instructions) ▶ _____</p> | <p>4 Exemptions (codes apply only to certain entities, not individuals; see instructions on page 3):</p> <p>Exempt payee code (if any) _____</p> <p>Exemption from FATCA reporting code (if any) _____</p> <p><small>(Applies to accounts maintained outside the U.S.)</small></p> |
| | <p>5 Address (number, street, and apt. or suite no.) See instructions.</p> | Requester's name and address (optional) |
| | <p>6 City, state, and ZIP code</p> | |
| | <p>7 List account number(s) here (optional)</p> | |

Part I Taxpayer Identification Number (TIN)

Enter your TIN in the appropriate box. The TIN provided must match the name given on line 1 to avoid backup withholding. For individuals, this is generally your social security number (SSN). However, for a resident alien, sole proprietor, or disregarded entity, see the instructions for Part I, later. For other entities, it is your employer identification number (EIN). If you do not have a number, see *How to get a TIN*, later.

Note: If the account is in more than one name, see the instructions for line 1. Also see *What Name and Number To Give the Requester* for guidelines on whose number to enter.

| | | | | | |
|------------------------------------------------------------------------------------------------------------------------------------------------------------------------------------------------------------------------------------------------------------------------------------------------------------------------------------------------------------------------------------------------|---|---|---|---|--|
| Social security number | | | | | |
| <table style="width: 100%; border-collapse: collapse;"> <tr> <td style="width: 25%; border: 1px solid black; height: 20px;"></td> <td style="width: 5%; text-align: center;">-</td> <td style="width: 25%; border: 1px solid black; height: 20px;"></td> <td style="width: 5%; text-align: center;">-</td> <td style="width: 40%; border: 1px solid black; height: 20px;"></td> </tr> </table> | | - | | - | |
| | - | | - | | |
| or | | | | | |
| Employer identification number | | | | | |
| <table style="width: 100%; border-collapse: collapse;"> <tr> <td style="width: 25%; border: 1px solid black; height: 20px;"></td> <td style="width: 5%; text-align: center;">-</td> <td style="width: 70%; border: 1px solid black; height: 20px;"></td> </tr> </table> | | - | | | |
| | - | | | | |

Part II Certification

Under penalties of perjury, I certify that:

1. The number shown on this form is my correct taxpayer identification number (or I am waiting for a number to be issued to me); and
2. I am not subject to backup withholding because: (a) I am exempt from backup withholding, or (b) I have not been notified by the Internal Revenue Service (IRS) that I am subject to backup withholding as a result of a failure to report all interest or dividends, or (c) the IRS has notified me that I am no longer subject to backup withholding; and
3. I am a U.S. citizen or other U.S. person (defined below); and
4. The FATCA code(s) entered on this form (if any) indicating that I am exempt from FATCA reporting is correct.

Certification instructions. You must cross out item 2 above if you have been notified by the IRS that you are currently subject to backup withholding because you have failed to report all interest and dividends on your tax return. For real estate transactions, item 2 does not apply. For mortgage interest paid, acquisition or abandonment of secured property, cancellation of debt, contributions to an individual retirement arrangement (IRA), and generally, payments other than interest and dividends, you are not required to sign the certification, but you must provide your correct TIN. See the instructions for Part II, later.

| | | |
|------------------|----------------------------------|--------------|
| Sign Here | Signature of U.S. person ▶ _____ | Date ▶ _____ |
|------------------|----------------------------------|--------------|

General Instructions

Section references are to the Internal Revenue Code unless otherwise noted.

Future developments. For the latest information about developments related to Form W-9 and its instructions, such as legislation enacted after they were published, go to www.irs.gov/FormW9.

Purpose of Form

An individual or entity (Form W-9 requester) who is required to file an information return with the IRS must obtain your correct taxpayer identification number (TIN) which may be your social security number (SSN), individual taxpayer identification number (ITIN), adoption taxpayer identification number (ATIN), or employer identification number (EIN), to report on an information return the amount paid to you, or other amount reportable on an information return. Examples of information returns include, but are not limited to, the following.

- Form 1099-INT (interest earned or paid)

- Form 1099-DIV (dividends, including those from stocks or mutual funds)
 - Form 1099-MISC (various types of income, prizes, awards, or gross proceeds)
 - Form 1099-B (stock or mutual fund sales and certain other transactions by brokers)
 - Form 1099-S (proceeds from real estate transactions)
 - Form 1099-K (merchant card and third party network transactions)
 - Form 1098 (home mortgage interest), 1098-E (student loan interest), 1098-T (tuition)
 - Form 1099-C (canceled debt)
 - Form 1099-A (acquisition or abandonment of secured property)
- Use Form W-9 only if you are a U.S. person (including a resident alien), to provide your correct TIN.
- If you do not return Form W-9 to the requester with a TIN, you might be subject to backup withholding. See What is backup withholding, later.*

By signing the filled-out form, you:

1. Certify that the TIN you are giving is correct (or you are waiting for a number to be issued),
2. Certify that you are not subject to backup withholding, or
3. Claim exemption from backup withholding if you are a U.S. exempt payee. If applicable, you are also certifying that as a U.S. person, your allocable share of any partnership income from a U.S. trade or business is not subject to the withholding tax on foreign partners' share of effectively connected income, and
4. Certify that FATCA code(s) entered on this form (if any) indicating that you are exempt from the FATCA reporting, is correct. See *What is FATCA reporting*, later, for further information.

Note: If you are a U.S. person and a requester gives you a form other than Form W-9 to request your TIN, you must use the requester's form if it is substantially similar to this Form W-9.

Definition of a U.S. person. For federal tax purposes, you are considered a U.S. person if you are:

- An individual who is a U.S. citizen or U.S. resident alien;
- A partnership, corporation, company, or association created or organized in the United States or under the laws of the United States;
- An estate (other than a foreign estate); or
- A domestic trust (as defined in Regulations section 301.7701-7).

Special rules for partnerships. Partnerships that conduct a trade or business in the United States are generally required to pay a withholding tax under section 1446 on any foreign partners' share of effectively connected taxable income from such business. Further, in certain cases where a Form W-9 has not been received, the rules under section 1446 require a partnership to presume that a partner is a foreign person, and pay the section 1446 withholding tax. Therefore, if you are a U.S. person that is a partner in a partnership conducting a trade or business in the United States, provide Form W-9 to the partnership to establish your U.S. status and avoid section 1446 withholding on your share of partnership income.

In the cases below, the following person must give Form W-9 to the partnership for purposes of establishing its U.S. status and avoiding withholding on its allocable share of net income from the partnership conducting a trade or business in the United States.

- In the case of a disregarded entity with a U.S. owner, the U.S. owner of the disregarded entity and not the entity;
- In the case of a grantor trust with a U.S. grantor or other U.S. owner, generally, the U.S. grantor or other U.S. owner of the grantor trust and not the trust; and
- In the case of a U.S. trust (other than a grantor trust), the U.S. trust (other than a grantor trust) and not the beneficiaries of the trust.

Foreign person. If you are a foreign person or the U.S. branch of a foreign bank that has elected to be treated as a U.S. person, do not use Form W-9. Instead, use the appropriate Form W-8 or Form 8233 (see Pub. 515, Withholding of Tax on Nonresident Aliens and Foreign Entities).

Nonresident alien who becomes a resident alien. Generally, only a nonresident alien individual may use the terms of a tax treaty to reduce or eliminate U.S. tax on certain types of income. However, most tax treaties contain a provision known as a "saving clause." Exceptions specified in the saving clause may permit an exemption from tax to continue for certain types of income even after the payee has otherwise become a U.S. resident alien for tax purposes.

If you are a U.S. resident alien who is relying on an exception contained in the saving clause of a tax treaty to claim an exemption from U.S. tax on certain types of income, you must attach a statement to Form W-9 that specifies the following five items.

1. The treaty country. Generally, this must be the same treaty under which you claimed exemption from tax as a nonresident alien.
2. The treaty article addressing the income.
3. The article number (or location) in the tax treaty that contains the saving clause and its exceptions.
4. The type and amount of income that qualifies for the exemption from tax.
5. Sufficient facts to justify the exemption from tax under the terms of the treaty article.

Example. Article 20 of the U.S.-China income tax treaty allows an exemption from tax for scholarship income received by a Chinese student temporarily present in the United States. Under U.S. law, this student will become a resident alien for tax purposes if his or her stay in the United States exceeds 5 calendar years. However, paragraph 2 of the first Protocol to the U.S.-China treaty (dated April 30, 1984) allows the provisions of Article 20 to continue to apply even after the Chinese student becomes a resident alien of the United States. A Chinese student who qualifies for this exception (under paragraph 2 of the first protocol) and is relying on this exception to claim an exemption from tax on his or her scholarship or fellowship income would attach to Form W-9 a statement that includes the information described above to support that exemption.

If you are a nonresident alien or a foreign entity, give the requester the appropriate completed Form W-8 or Form 8233.

Backup Withholding

What is backup withholding? Persons making certain payments to you must under certain conditions withhold and pay to the IRS 24% of such payments. This is called "backup withholding." Payments that may be subject to backup withholding include interest, tax-exempt interest, dividends, broker and barter exchange transactions, rents, royalties, nonemployee pay, payments made in settlement of payment card and third party network transactions, and certain payments from fishing boat operators. Real estate transactions are not subject to backup withholding.

You will not be subject to backup withholding on payments you receive if you give the requester your correct TIN, make the proper certifications, and report all your taxable interest and dividends on your tax return.

Payments you receive will be subject to backup withholding if:

1. You do not furnish your TIN to the requester,
2. You do not certify your TIN when required (see the instructions for Part II for details),
3. The IRS tells the requester that you furnished an incorrect TIN,
4. The IRS tells you that you are subject to backup withholding because you did not report all your interest and dividends on your tax return (for reportable interest and dividends only), or
5. You do not certify to the requester that you are not subject to backup withholding under 4 above (for reportable interest and dividend accounts opened after 1983 only).

Certain payees and payments are exempt from backup withholding. See *Exempt payee code*, later, and the separate instructions for the Requester of Form W-9 for more information.

Also see *Special rules for partnerships*, earlier.

What is FATCA Reporting?

The Foreign Account Tax Compliance Act (FATCA) requires a participating foreign financial institution to report all United States account holders that are specified United States persons. Certain payees are exempt from FATCA reporting. See *Exemption from FATCA reporting code*, later, and the Instructions for the Requester of Form W-9 for more information.

Updating Your Information

You must provide updated information to any person to whom you claimed to be an exempt payee if you are no longer an exempt payee and anticipate receiving reportable payments in the future from this person. For example, you may need to provide updated information if you are a C corporation that elects to be an S corporation, or if you no longer are tax exempt. In addition, you must furnish a new Form W-9 if the name or TIN changes for the account; for example, if the grantor of a grantor trust dies.

Penalties

Failure to furnish TIN. If you fail to furnish your correct TIN to a requester, you are subject to a penalty of \$50 for each such failure unless your failure is due to reasonable cause and not to willful neglect.

Civil penalty for false information with respect to withholding. If you make a false statement with no reasonable basis that results in no backup withholding, you are subject to a \$500 penalty.

Criminal penalty for falsifying information. Willfully falsifying certifications or affirmations may subject you to criminal penalties including fines and/or imprisonment.

Misuse of TINs. If the requester discloses or uses TINs in violation of federal law, the requester may be subject to civil and criminal penalties.

Specific Instructions

Line 1

You must enter one of the following on this line; **do not** leave this line blank. The name should match the name on your tax return.

If this Form W-9 is for a joint account (other than an account maintained by a foreign financial institution (FFI)), list first, and then circle, the name of the person or entity whose number you entered in Part I of Form W-9. If you are providing Form W-9 to an FFI to document a joint account, each holder of the account that is a U.S. person must provide a Form W-9.

a. **Individual.** Generally, enter the name shown on your tax return. If you have changed your last name without informing the Social Security Administration (SSA) of the name change, enter your first name, the last name as shown on your social security card, and your new last name.

Note: ITIN applicant: Enter your individual name as it was entered on your Form W-7 application, line 1a. This should also be the same as the name you entered on the Form 1040/1040A/1040EZ you filed with your application.

b. **Sole proprietor or single-member LLC.** Enter your individual name as shown on your 1040/1040A/1040EZ on line 1. You may enter your business, trade, or "doing business as" (DBA) name on line 2.

c. **Partnership, LLC that is not a single-member LLC, C corporation, or S corporation.** Enter the entity's name as shown on the entity's tax return on line 1 and any business, trade, or DBA name on line 2.

d. **Other entities.** Enter your name as shown on required U.S. federal tax documents on line 1. This name should match the name shown on the charter or other legal document creating the entity. You may enter any business, trade, or DBA name on line 2.

e. **Disregarded entity.** For U.S. federal tax purposes, an entity that is disregarded as an entity separate from its owner is treated as a "disregarded entity." See Regulations section 301.7701-2(c)(2)(iii). Enter the owner's name on line 1. The name of the entity entered on line 1 should never be a disregarded entity. The name on line 1 should be the name shown on the income tax return on which the income should be reported. For example, if a foreign LLC that is treated as a disregarded entity for U.S. federal tax purposes has a single owner that is a U.S. person, the U.S. owner's name is required to be provided on line 1. If the direct owner of the entity is also a disregarded entity, enter the first owner that is not disregarded for federal tax purposes. Enter the disregarded entity's name on line 2, "Business name/disregarded entity name." If the owner of the disregarded entity is a foreign person, the owner must complete an appropriate Form W-8 instead of a Form W-9. This is the case even if the foreign person has a U.S. TIN.

Line 2

If you have a business name, trade name, DBA name, or disregarded entity name, you may enter it on line 2.

Line 3

Check the appropriate box on line 3 for the U.S. federal tax classification of the person whose name is entered on line 1. Check only one box on line 3.

| IF the entity/person on line 1 is a(n) . . . | THEN check the box for . . . |
|--------------------------------------------------------------------------------------------------------------------------------------------------------------------------------------------------------------------------------------------------------------------------------------------------------------------------------------------------------------|---------------------------------------------------------------------------------------------------------------------------------|
| <ul style="list-style-type: none"> • Corporation | Corporation |
| <ul style="list-style-type: none"> • Individual • Sole proprietorship, or • Single-member limited liability company (LLC) owned by an individual and disregarded for U.S. federal tax purposes. | Individual/sole proprietor or single-member LLC |
| <ul style="list-style-type: none"> • LLC treated as a partnership for U.S. federal tax purposes, • LLC that has filed Form 8832 or 2553 to be taxed as a corporation, or • LLC that is disregarded as an entity separate from its owner but the owner is another LLC that is not disregarded for U.S. federal tax purposes. | Limited liability company and enter the appropriate tax classification. (P= Partnership; C= C corporation; or S= S corporation) |
| <ul style="list-style-type: none"> • Partnership | Partnership |
| <ul style="list-style-type: none"> • Trust/estate | Trust/estate |

Line 4, Exemptions

If you are exempt from backup withholding and/or FATCA reporting, enter in the appropriate space on line 4 any code(s) that may apply to you.

Exempt payee code.

- Generally, individuals (including sole proprietors) are not exempt from backup withholding.
- Except as provided below, corporations are exempt from backup withholding for certain payments, including interest and dividends.
- Corporations are not exempt from backup withholding for payments made in settlement of payment card or third party network transactions.
- Corporations are not exempt from backup withholding with respect to attorneys' fees or gross proceeds paid to attorneys, and corporations that provide medical or health care services are not exempt with respect to payments reportable on Form 1099-MISC.

The following codes identify payees that are exempt from backup withholding. Enter the appropriate code in the space in line 4.

- 1—An organization exempt from tax under section 501(a), any IRA, or a custodial account under section 403(b)(7) if the account satisfies the requirements of section 401(f)(2)
- 2—The United States or any of its agencies or instrumentalities
- 3—A state, the District of Columbia, a U.S. commonwealth or possession, or any of their political subdivisions or instrumentalities
- 4—A foreign government or any of its political subdivisions, agencies, or instrumentalities
- 5—A corporation
- 6—A dealer in securities or commodities required to register in the United States, the District of Columbia, or a U.S. commonwealth or possession
- 7—A futures commission merchant registered with the Commodity Futures Trading Commission
- 8—A real estate investment trust
- 9—An entity registered at all times during the tax year under the Investment Company Act of 1940
- 10—A common trust fund operated by a bank under section 584(a)
- 11—A financial institution
- 12—A middleman known in the investment community as a nominee or custodian
- 13—A trust exempt from tax under section 664 or described in section 4947

The following chart shows types of payments that may be exempt from backup withholding. The chart applies to the exempt payees listed above, 1 through 13.

| IF the payment is for . . . | THEN the payment is exempt for . . . |
|----------------------------------------------------------------------------------------|---------------------------------------------------------------------------------------------------------------------------------------------------------------------------------------------------------------|
| Interest and dividend payments | All exempt payees except for 7 |
| Broker transactions | Exempt payees 1 through 4 and 6 through 11 and all C corporations. S corporations must not enter an exempt payee code because they are exempt only for sales of noncovered securities acquired prior to 2012. |
| Barter exchange transactions and patronage dividends | Exempt payees 1 through 4 |
| Payments over \$600 required to be reported and direct sales over \$5,000 ¹ | Generally, exempt payees 1 through 5 ² |
| Payments made in settlement of payment card or third party network transactions | Exempt payees 1 through 4 |

¹ See Form 1099-MISC, Miscellaneous Income, and its instructions.

² However, the following payments made to a corporation and reportable on Form 1099-MISC are not exempt from backup withholding: medical and health care payments, attorneys' fees, gross proceeds paid to an attorney reportable under section 6045(f), and payments for services paid by a federal executive agency.

Exemption from FATCA reporting code. The following codes identify payees that are exempt from reporting under FATCA. These codes apply to persons submitting this form for accounts maintained outside of the United States by certain foreign financial institutions. Therefore, if you are only submitting this form for an account you hold in the United States, you may leave this field blank. Consult with the person requesting this form if you are uncertain if the financial institution is subject to these requirements. A requester may indicate that a code is not required by providing you with a Form W-9 with "Not Applicable" (or any similar indication) written or printed on the line for a FATCA exemption code.

A—An organization exempt from tax under section 501(a) or any individual retirement plan as defined in section 7701(a)(37)

B—The United States or any of its agencies or instrumentalities

C—A state, the District of Columbia, a U.S. commonwealth or possession, or any of their political subdivisions or instrumentalities

D—A corporation the stock of which is regularly traded on one or more established securities markets, as described in Regulations section 1.1472-1(c)(1)(i)

E—A corporation that is a member of the same expanded affiliated group as a corporation described in Regulations section 1.1472-1(c)(1)(i)

F—A dealer in securities, commodities, or derivative financial instruments (including notional principal contracts, futures, forwards, and options) that is registered as such under the laws of the United States or any state

G—A real estate investment trust

H—A regulated investment company as defined in section 851 or an entity registered at all times during the tax year under the Investment Company Act of 1940

I—A common trust fund as defined in section 584(a)

J—A bank as defined in section 581

K—A broker

L—A trust exempt from tax under section 664 or described in section 4947(a)(1)

M—A tax exempt trust under a section 403(b) plan or section 457(g) plan

Note: You may wish to consult with the financial institution requesting this form to determine whether the FATCA code and/or exempt payee code should be completed.

Line 5

Enter your address (number, street, and apartment or suite number). This is where the requester of this Form W-9 will mail your information returns. If this address differs from the one the requester already has on file, write NEW at the top. If a new address is provided, there is still a chance the old address will be used until the payor changes your address in their records.

Line 6

Enter your city, state, and ZIP code.

Part I. Taxpayer Identification Number (TIN)

Enter your TIN in the appropriate box. If you are a resident alien and you do not have and are not eligible to get an SSN, your TIN is your IRS individual taxpayer identification number (ITIN). Enter it in the social security number box. If you do not have an ITIN, see *How to get a TIN* below.

If you are a sole proprietor and you have an EIN, you may enter either your SSN or EIN.

If you are a single-member LLC that is disregarded as an entity separate from its owner, enter the owner's SSN (or EIN, if the owner has one). Do not enter the disregarded entity's EIN. If the LLC is classified as a corporation or partnership, enter the entity's EIN.

Note: See *What Name and Number To Give the Requester*, later, for further clarification of name and TIN combinations.

How to get a TIN. If you do not have a TIN, apply for one immediately. To apply for an SSN, get Form SS-5, Application for a Social Security Card, from your local SSA office or get this form online at www.SSA.gov. You may also get this form by calling 1-800-772-1213. Use Form W-7, Application for IRS Individual Taxpayer Identification Number, to apply for an ITIN, or Form SS-4, Application for Employer Identification Number, to apply for an EIN. You can apply for an EIN online by accessing the IRS website at www.irs.gov/Businesses and clicking on Employer Identification Number (EIN) under Starting a Business. Go to www.irs.gov/Forms to view, download, or print Form W-7 and/or Form SS-4. Or, you can go to www.irs.gov/OrderForms to place an order and have Form W-7 and/or SS-4 mailed to you within 10 business days.

If you are asked to complete Form W-9 but do not have a TIN, apply for a TIN and write "Applied For" in the space for the TIN, sign and date the form, and give it to the requester. For interest and dividend payments, and certain payments made with respect to readily tradable instruments, generally you will have 60 days to get a TIN and give it to the requester before you are subject to backup withholding on payments. The 60-day rule does not apply to other types of payments. You will be subject to backup withholding on all such payments until you provide your TIN to the requester.

Note: Entering "Applied For" means that you have already applied for a TIN or that you intend to apply for one soon.

Caution: A disregarded U.S. entity that has a foreign owner must use the appropriate Form W-8.

Part II. Certification

To establish to the withholding agent that you are a U.S. person, or resident alien, sign Form W-9. You may be requested to sign by the withholding agent even if item 1, 4, or 5 below indicates otherwise.

For a joint account, only the person whose TIN is shown in Part I should sign (when required). In the case of a disregarded entity, the person identified on line 1 must sign. Exempt payees, see *Exempt payee code*, earlier.

Signature requirements. Complete the certification as indicated in items 1 through 5 below.

1. Interest, dividend, and barter exchange accounts opened before 1984 and broker accounts considered active during 1983. You must give your correct TIN, but you do not have to sign the certification.

2. Interest, dividend, broker, and barter exchange accounts opened after 1983 and broker accounts considered inactive during 1983. You must sign the certification or backup withholding will apply. If you are subject to backup withholding and you are merely providing your correct TIN to the requester, you must cross out item 2 in the certification before signing the form.

3. Real estate transactions. You must sign the certification. You may cross out item 2 of the certification.

4. Other payments. You must give your correct TIN, but you do not have to sign the certification unless you have been notified that you have previously given an incorrect TIN. "Other payments" include payments made in the course of the requester's trade or business for rents, royalties, goods (other than bills for merchandise), medical and health care services (including payments to corporations), payments to a nonemployee for services, payments made in settlement of payment card and third party network transactions, payments to certain fishing boat crew members and fishermen, and gross proceeds paid to attorneys (including payments to corporations).

5. Mortgage interest paid by you, acquisition or abandonment of secured property, cancellation of debt, qualified tuition program payments (under section 529), ABLE accounts (under section 529A), IRA, Coverdell ESA, Archer MSA or HSA contributions or distributions, and pension distributions. You must give your correct TIN, but you do not have to sign the certification.

What Name and Number To Give the Requester

| For this type of account: | Give name and SSN of: |
|----------------------------------------------------------------------------------------------------------------------------------------------------|---------------------------------------------------------------------------------------------------------|
| 1. Individual | The individual |
| 2. Two or more individuals (joint account) other than an account maintained by an FFI | The actual owner of the account or, if combined funds, the first individual on the account ¹ |
| 3. Two or more U.S. persons (joint account maintained by an FFI) | Each holder of the account |
| 4. Custodial account of a minor (Uniform Gift to Minors Act) | The minor ² |
| 5. a. The usual revocable savings trust (grantor is also trustee) b. So-called trust account that is not a legal or valid trust under state law | The grantor-trustee ¹ The actual owner ¹ |
| 6. Sole proprietorship or disregarded entity owned by an individual | The owner ³ |
| 7. Grantor trust filing under Optional Form 1099 Filing Method 1 (see Regulations section 1.671-4(b)(2)(i)(A)) | The grantor ⁴ |

| For this type of account: | Give name and EIN of: |
|---------------------------------------------------------------------------------------------|---------------------------|
| 8. Disregarded entity not owned by an individual | The owner |
| 9. A valid trust, estate, or pension trust | Legal entity ⁴ |
| 10. Corporation or LLC electing corporate status on Form 8832 or Form 2553 | The corporation |
| 11. Association, club, religious, charitable, educational, or other tax-exempt organization | The organization |
| 12. Partnership or multi-member LLC | The partnership |
| 13. A broker or registered nominee | The broker or nominee |

| For this type of account: | Give name and EIN of: |
|---------------------------------------------------------------------------------------------------------------------------------------------------------------------------------------------|-----------------------|
| 14. Account with the Department of Agriculture in the name of a public entity (such as a state or local government, school district, or prison) that receives agricultural program payments | The public entity |
| 15. Grantor trust filing under the Form 1041 Filing Method or the Optional Form 1099 Filing Method 2 (see Regulations section 1.671-4(b)(2)(i)(B)) | The trust |

¹ List first and circle the name of the person whose number you furnish. If only one person on a joint account has an SSN, that person's number must be furnished.

² Circle the minor's name and furnish the minor's SSN.

³ You must show your individual name and you may also enter your business or DBA name on the "Business name/disregarded entity" name line. You may use either your SSN or EIN (if you have one), but the IRS encourages you to use your SSN.

⁴ List first and circle the name of the trust, estate, or pension trust. (Do not furnish the TIN of the personal representative or trustee unless the legal entity itself is not designated in the account title.) Also see *Special rules for partnerships*, earlier.

*Note: The grantor also must provide a Form W-9 to trustee of trust.

Note: If no name is circled when more than one name is listed, the number will be considered to be that of the first name listed.

Secure Your Tax Records From Identity Theft

Identity theft occurs when someone uses your personal information such as your name, SSN, or other identifying information, without your permission, to commit fraud or other crimes. An identity thief may use your SSN to get a job or may file a tax return using your SSN to receive a refund.

To reduce your risk:

- Protect your SSN,
- Ensure your employer is protecting your SSN, and
- Be careful when choosing a tax preparer.

If your tax records are affected by identity theft and you receive a notice from the IRS, respond right away to the name and phone number printed on the IRS notice or letter.

If your tax records are not currently affected by identity theft but you think you are at risk due to a lost or stolen purse or wallet, questionable credit card activity or credit report, contact the IRS Identity Theft Hotline at 1-800-908-4490 or submit Form 14039.

For more information, see Pub. 5027, Identity Theft Information for Taxpayers.

Victims of identity theft who are experiencing economic harm or a systemic problem, or are seeking help in resolving tax problems that have not been resolved through normal channels, may be eligible for Taxpayer Advocate Service (TAS) assistance. You can reach TAS by calling the TAS toll-free case intake line at 1-877-777-4778 or TTY/TDD 1-800-829-4059.

Protect yourself from suspicious emails or phishing schemes. Phishing is the creation and use of email and websites designed to mimic legitimate business emails and websites. The most common act is sending an email to a user falsely claiming to be an established legitimate enterprise in an attempt to scam the user into surrendering private information that will be used for identity theft.

The IRS does not initiate contacts with taxpayers via emails. Also, the IRS does not request personal detailed information through email or ask taxpayers for the PIN numbers, passwords, or similar secret access information for their credit card, bank, or other financial accounts.

If you receive an unsolicited email claiming to be from the IRS, forward this message to phishing@irs.gov. You may also report misuse of the IRS name, logo, or other IRS property to the Treasury Inspector General for Tax Administration (TIGTA) at 1-800-366-4484. You can forward suspicious emails to the Federal Trade Commission at spam@uce.gov or report them at www.ftc.gov/complaint. You can contact the FTC at www.ftc.gov/idtheft or 877-IDTHEFT (877-438-4338). If you have been the victim of identity theft, see www.IdentityTheft.gov and Pub. 5027.

Visit www.irs.gov/IdentityTheft to learn more about identity theft and how to reduce your risk.

Privacy Act Notice

Section 6109 of the Internal Revenue Code requires you to provide your correct TIN to persons (including federal agencies) who are required to file information returns with the IRS to report interest, dividends, or certain other income paid to you; mortgage interest you paid; the acquisition or abandonment of secured property; the cancellation of debt; or contributions you made to an IRA, Archer MSA, or HSA. The person collecting this form uses the information on the form to file information returns with the IRS, reporting the above information. Routine uses of this information include giving it to the Department of Justice for civil and criminal litigation and to cities, states, the District of Columbia, and U.S. commonwealths and possessions for use in administering their laws. The information also may be disclosed to other countries under a treaty, to federal and state agencies to enforce civil and criminal laws, or to federal law enforcement and intelligence agencies to combat terrorism. You must provide your TIN whether or not you are required to file a tax return. Under section 3406, payers must generally withhold a percentage of taxable interest, dividend, and certain other payments to a payee who does not give a TIN to the payer. Certain penalties may also apply for providing false or fraudulent information.

C. 271 POLITICAL CONTRIBUTION DISCLOSURE FORM

Contractor Instructions

Business entities (contractors) receiving contracts from a public agency that are NOT awarded pursuant to a “fair and open” process (defined at N.J.S.A. 19:44A-20.7) are subject to the provisions of P.L. 2005, c. 271, s.2 (N.J.S.A. 19:44A-20.26). This law provides that 10 days prior to the award of such a contract, the contractor shall disclose contributions to:

- any State, county, or municipal committee of a political party
- any legislative leadership committee*
- any continuing political committee (a.k.a., political action committee)
- any candidate committee of a candidate for, or holder of, an elective office:
 - of the public entity awarding the contract
 - of that county in which that public entity is located
 - of another public entity within that county
 - or of a legislative district in which that public entity is located or, when the public entity is a county, of any legislative district which includes all or part of the county

The disclosure must list reportable contributions to any of the committees that exceed \$300 per election cycle that were made during the 12 months prior to award of the contract. See N.J.S.A. 19:44A-8 and 19:44A-16 for more details on reportable contributions.

N.J.S.A. 52:34-25(b) itemizes the parties from whom contributions must be disclosed when a business entity is not a natural person. This includes the following:

- individuals with an “interest:” ownership or control of more than 10% of the profits or assets of a business entity or 10% of the stock in the case of a business entity that is a corporation for profit
- all principals, partners, officers, or directors of the business entity or their spouses
- any subsidiaries directly or indirectly controlled by the business entity
- IRS Code Section 527 New Jersey based organizations, directly or indirectly controlled by the business entity and filing as continuing political committees, (PACs).

When the business entity is a natural person, “a contribution by that person’s spouse or child, residing therewith, shall be deemed to be a contribution by the business entity.” [N.J.S.A. 19:44A-20.26(b)] The contributor must be listed on the disclosure.

Any business entity that fails to comply with the disclosure provisions shall be subject to a fine imposed by ELEC in an amount to be determined by the Commission which may be based upon the amount that the business entity failed to report.

The enclosed list of agencies is provided to assist the contractor in identifying those public agencies whose elected official and/or candidate campaign committees are affected by the disclosure requirement. It is the contractor’s responsibility to identify the specific committees to which contributions may have been made and need to be disclosed. The disclosed information may exceed the minimum requirement.

The enclosed form, a content-consistent facsimile, or an electronic data file containing the required details (along with a signed cover sheet) may be used as the contractor’s submission and is disclosable to the public under the Open Public Records Act.

The contractor must also complete the attached Stockholder Disclosure Certification. This will assist the agency in meeting its obligations under the law.

¹ N.J.S.A. 19:44A-3(s): “The term “legislative leadership committee” means a committee established, authorized to be established, or designated by the President of the Senate, the Minority Leader of the Senate, the Speaker of the General Assembly or the Minority Leader of the General Assembly pursuant to section 16 of P.L.1993, c.65 (C.19:44A-10.1) for the purpose of receiving contributions and making expenditures.”

MONTGOMERY TOWNSHIP BOARD OF EDUCATION
1014 ROUTE 601
SKILLMAN, NEW JERSEY 08558
PHONE: (609) 466-7601
FAX: (609) 466-0944

List of Agencies with Elected Officials Required for Political Contribution Disclosure
N.J.S.A. 19:44A-20.26

County Name: Somerset

State: Governor, and Legislative Leadership Committees

Legislative District #s: 16, 17, 21, & 22

State Senator and two members of the General Assembly per district.

County:

Freeholders

County Clerk

Sheriff

Surrogate

Municipalities (Mayor and members of governing body, regardless of title):

Bedminster Township

Bernards Township

Bernardsville Borough

Bound Brook Borough

Branchburg Township

Bridgewater Township

Far Hills Borough

Franklin Township

Green Brook Township

Hillsborough Township

Manville Borough

Millstone Borough

Montgomery Township

North Plainfield Borough

Peapack-Gladstone Borough

Raritan Borough

Rocky Hill Borough

Somerville Borough

South Bound Brook Borough

Warren Township

Watchung Borough

Boards of Education (Members of the Board):

Bedminster Township

Bernards Township

Bound Brook Borough

Branchburg Township

Bridgewater-Raritan Regional

Franklin Township

Green Brook Township

Hillsborough Township

Manville Borough

Millstone

Montgomery Township

North Plainfield Borough

Rocky Hill

Somerset Hills Regional

Somerville Borough

South Bound Brook

Warren Township

Watchung Borough

Watchung Hills Regional

Fire Districts (Board of Fire Commissioners):

Bridgewater Township Fire District No. 1

Bridgewater Township Fire District No. 2

Bridgewater Township Fire District No. 3

Bridgewater Township Fire District No. 4

Franklin Township Fire District No. 1

Franklin Township Fire District No. 2

Franklin Township Fire District No. 3

Franklin Township Fire District No. 4

Hillsborough Township Fire District No. 1

Montgomery Township Fire District No. 1

Montgomery Township Fire District No. 2

C. 271 POLITICAL CONTRIBUTION DISCLOSURE FORM

Required Pursuant To N.J.S.A. 19:44A-20.26

This form or its permitted facsimile must be submitted to the local unit no later than 10 days prior to the award of the contract.

Part I – Vendor Information

| | | | |
|--------------|--|--------|------|
| Vendor Name: | | | |
| Address: | | | |
| City: | | State: | Zip: |

The undersigned being authorized to certify, hereby certifies that the submission provided herein represents compliance with the provisions of N.J.S.A. 19:44A-20.26 and as represented by the Instructions accompanying this form.

| | | |
|-----------|--------------|-------|
| Signature | Printed Name | Title |
|-----------|--------------|-------|

Part II – Contribution Disclosure

Disclosure requirement: Pursuant to N.J.S.A. 19:44A-20.26 this disclosure must include all reportable political contributions (more than \$300 per election cycle) over the 12 months prior to submission to the committees of the government entities listed on the form provided by the local unit.

Check here if disclosure is provided in electronic form.

| Contributor Name | Recipient Name | Date | Dollar Amount |
|------------------|----------------|------|---------------|
| | | | \$ |
| | | | |
| | | | |
| | | | |
| | | | |
| | | | |
| | | | |
| | | | |
| | | | |
| | | | |
| | | | |
| | | | |
| | | | |
| | | | |
| | | | |
| | | | |
| | | | |
| | | | |
| | | | |
| | | | |
| | | | |

Check here if the information is continued on subsequent page(s)

**MONTGOMERY TOWNSHIP BOARD OF EDUCATION
DISCLOSURE OF INVESTMENT ACTIVITIES IN IRAN**

Bid Number: _____

Name of Bidder: _____

Pursuant to Public Law 2012, c. 25, any person or entity that submits a bid or proposal or otherwise proposes to enter into or renew a contract must complete the certification below to attest, under penalty of perjury, that the person or entity, or one of the person or entity's parents, subsidiaries, or affiliates, is not identified on a list created and maintained by the Department of the Treasury as a person or entity engaging in investment activities in Iran. If the District finds a person or entity to be in violation of the principles which are the subject of this law, they shall take action as may be appropriate and provided by law, rule or contract, including but not limited to, imposing sanctions, seeking compliance, recovering damages, declaring the party in default and seeking debarment or suspension of the person or entity.

I certify, pursuant to Public Law 2012, c. 25, that the person or entity listed above for which I am authorized to bid/renew:

is not providing goods or services of \$20,000,000 or more in the energy sector of Iran, including a person or entity that provides oil or liquefied natural gas tankers, or products used to construct or maintain pipelines used to transport oil or liquefied natural gas, for the energy sector of Iran,

OR

is not a financial institution that extends \$20,000,000 or more in credit to another person or entity for 45 days or more, if that person or entity will use the credit to provide goods or services in the energy sector in Iran.

In the event that a person or entity is unable to make the above certification because it or one of its parents, subsidiaries, or affiliates has engaged in the above-referenced activities, a detailed, accurate and precise description of the activities must be provided in Part 2 below to the Montgomery Township Board of Education under penalty of perjury. Failure to provide such will result in the proposal being rendered as non-responsive and appropriate penalties, fines and/or sanctions will be assessed as provided by law.

**PART 2:
PLEASE PROVIDE FURTHER INFORMATION RELATED TO INVESTMENT ACTIVITIES IN IRAN**

You must provide a detailed, accurate and precise description of the activities of the bidding person/entity, or one of its parents, subsidiaries or affiliates, engaging in the investment activities in Iran outlined above by completing the boxes below.

EACH BOX WILL PROMPT YOU TO PROVIDE INFORMATION RELATIVE TO THE ABOVE QUESTIONS. PLEASE PROVIDE THOROUGH ANSWERS TO EACH QUESTION.

| |
|-----------------------------------------------------------------|
| Name: _____ Relationship to Bidder/Offeror: _____ |
| Description of Activities: _____ _____ |
| Duration of Engagement: _____ Anticipated Cessation Date: _____ |
| Bidder/Offeror Contact Name: _____ Contact Phone Number: _____ |

Disclosure of Investment Activities in Iran (cont'd)

Certification: I, being duly sworn upon my oath, hereby represent and state that the foregoing information and any attachments thereto to the best of my knowledge are true and complete. I attest that I am authorized to execute this certification on behalf of the above-referenced person or entity. I acknowledge that the Montgomery Township Board of Education is relying on the information contained herein and thereby acknowledge that I am under a continuing obligation from the date of this certification through the completion of any contracts with the Board to notify the Board in writing of any changes to the answers of information contained herein. I acknowledge that I am aware that it is a criminal offense to make a false statement or misrepresentation in this certification, and if I do so, I recognize that I am subject to criminal prosecution under the law and that it will also constitute a material breach of my agreement(s) with the Montgomery Township Board of Education and that the Board at its option may declare any contract(s) resulting from this certification void and unenforceable.

Full Name (Print): _____ Signature: _____

Title: _____ Date: _____

**CERTIFICATION OF NON-DEBARMENT
FOR FEDERAL GOVERNMENT CONTRACTS**
N.J.S.A. 52:32-44.1 (P.L. 2019, c.406)

This certification shall be completed, certified to, and submitted to the contracting unit prior to contract award, except for emergency contracts where submission is required prior to payment.

| PART I: VENDOR INFORMATION | |
|-------------------------------------------------------------------------|--|
| Individual or Organization Name | |
| Address of Individual or Organization | |
| DUNS Code (if applicable) | |
| CAGE Code (if applicable) | |
| Check the box that represents the type of business organization: | |

- Sole Proprietorship (skip Parts III and IV)
 Non-Profit Corporation (skip Parts III and IV)
 For-Profit Corporation (any type)
 Limited Liability Company (LLC)
 Partnership
 Limited Partnership
 Limited Liability Partnership (LLP)
 Other (be specific): _____

| PART II – CERTIFICATION OF NON-DEBARMENT: Individual or Organization | | | |
|---------------------------------------------------------------------------------------------------------------------------------------------------------------------------------------------------------------------------------------------------------------------------------------------------------------------------------------------------------------------------------------------------------------------------------------------------------------------------------------------------------------------------------------------------------------------------------------------------------------------------------------------------------------------------------------------------------------------------------------------------------------------------------------------------------------------------------------------------------------------------------------------------------------------------------------------------------------------------------------------------------------------------------------------------------------------|--|--------|--|
| I hereby certify that the individual or organization listed above in Part I is not debarred by the federal government from contracting with a federal agency. I further acknowledge: that I am authorized to execute this certification on behalf of the above-named organization; that the Montgomery Township Board of Education is relying on the information contained herein and that I am under a continuing obligation from the date of this certification through the date of contract award by school district to notify the school district in writing of any changes to the information contained herein; that I am aware that it is a criminal offense to make a false statement or misrepresentation in this certification, and if I do so, I am subject to criminal prosecution under the law and that it will constitute a material breach of my agreement(s) with the school district permitting the school district to declare any contract(s) resulting from this certification void and unenforceable. | | | |
| Full Name (Print): | | Title: | |
| Signature: | | Date: | |

PART III – CERTIFICATION OF NON-DEBARMENT: Individual or Entity Owning Greater than 50 Percent of Organization

Section A (Check the Box that applies)

| | |
|----------------------------------------------------------|---------------------------------------------------------------------------------------------------------------------------------------------------------------------------------------------------------------------------------------------------------------------------------------------------------------------------------|
| <input type="checkbox"/> | Below is the name and address of the stockholder in the corporation who owns more than 50 percent of its voting stock, or of the partner in the partnership who owns more than 50 percent interest therein, or of the member of the limited liability company owning more than 50 percent interest therein, as the case may be. |
| Name of Individual or Organization | |
| Home Address (for Individual) or Business Address | |
| OR | |
| <input type="checkbox"/> | No one stockholder in the corporation owns more than 50 percent of its voting stock, or no partner in the partnership owns more than 50 percent interest therein, or no member in the limited liability company owns more than 50 percent interest therein, as the case may be. |

Section B (Skip if no Business entity is listed in Section A above)

| | |
|-----------------------------------------------------------------------------------|-------------------------------------------------------------------------------------------------------------------------------------------------------------------------------------------------------------------------------------------------------------------------------------------------------------------------------------------------------------------------------------------------------------------------|
| <input type="checkbox"/> | Below is the name and address of the stockholder in the corporation who owns more than 50 percent of the voting stock of the organization’s parent entity, or of the partner in the partnership who owns more than 50 percent interest in the organization’s parent entity, or of the member of the limited liability company owning more than 50 percent interest in organization’s parent entity, as the case may be. |
| Stockholder/Partner/Member Owning Greater Than 50 Percent of Parent Entity | |
| Home Address (for Individual) or Business Address | |
| OR | |
| <input type="checkbox"/> | No one stockholder in the parent entity corporation owns more than 50 percent of its voting stock, no partner in the parent entity partnership owns more than 50 percent interest therein, or no member in the parent entity limited liability company owns more than 50 percent interest therein, as the case may be. |

Section C – Part III Certification

I hereby certify that no individual or organization that is debarred by the federal government from contracting with a federal agency owns greater than 50 percent of the **organization listed above in Part I** or, if applicable, owns greater than 50 percent of a parent entity of the **organization listed above in Part I**. I further acknowledge: that I am authorized to execute this certification on behalf of the above-named organization; that the **Montgomery Township Board of Education** is relying on the information contained herein and that I am under a continuing obligation from the date of this certification through the date of contract award **school district** to notify the **school district** in writing of any changes to the information contained herein; that I am aware that it is a criminal offense to make a false statement or misrepresentation in this certification, and if I do so, I am subject to criminal prosecution under the law and that it will constitute a material breach of my agreement(s) with the **school district** permitting the **school district** to declare any contract(s) resulting from this certification void and unenforceable.

| | | | |
|--------------------|--|--------|--|
| Full Name (Print): | | Title: | |
| Signature: | | Date: | |

Part IV – CERTIFICATION OF NON-DEBARMENT: Contractor – Controlled Entities

Section A



Below is the name and address of the corporation(s) in which the **Organization listed in Part I** owns more than 50 percent of voting stock, or of the partnership(s) in which the **Organization listed in Part I** owns more than 50 percent interest therein, or of the limited liability company or companies in which the **Organization listed above in Part I** owns more than 50 percent interest therein, as the case may be.

Name of Business Entity

Business Address

| | |
|--|--|
| | |
| | |
| | |

****Add additional sheets if necessary****

OR



The **Organization listed above in Part I** does not own greater than 50 percent of the voting stock in any corporation and does not own greater than 50 percent interest in any partnership or any limited liability company.

| Section B (skip if no business entities are listed in Section A of Part IV) | | | |
|---------------------------------------------------------------------------------------------------------------------------------------------------------------------------------------------------------------------------------------------------------------------------------------------------------------------------------------------------------------------------------------------------------------------------------------------------------------------------------------------------------------------------------------------------------------------------------------------------------------------------------------------------------------------------------------------------------------------------------------------------------------------------------------------------------------------------------------------------------------------------------------------------------------------------------------------------------------------------------------------------------------------------------------------------------------------------------------------------------------------------------------------------------------------------------------------------------------------------------------------------------------------------------------------------------------------------------|-----------------------------------------------------------------------------------------------------------------------------------------------------------------------------------------------------------------------------------------------|-------------------------|--|
| <input type="checkbox"/> | Below are the names and addresses of any entities in which an entity listed in Part III A owns greater than 50 percent of the voting stock (corporation) or owns greater than 50 percent interest (partnership or limited liability company). | | |
| Name of Business Entity Controlled by Entity Listed in Section A of Part IV | | Business Address | |
| | | | |
| | | | |
| | | | |
| **Add additional Sheets if necessary** | | | |
| OR | | | |
| <input type="checkbox"/> | No entity listed in Part III A owns greater than 50 percent of the voting stock in any corporation or owns greater than 50 percent interest in any partnership or limited liability company. | | |
| Section C – Part IV Certification | | | |
| <p>I hereby certify that the Organization listed above in Part I does not own greater than 50 percent of any entity that that is debarred by the federal government from contracting with a federal agency and, if applicable, does not own greater than 50 percent of any entity that in turns owns greater than 50 percent of any entity debarred by the federal government from contracting with a federal agency. I further acknowledge: that I am authorized to execute this certification on behalf of the above-named organization; that the Montgomery Township Board of Education is relying on the information contained herein and that I am under a continuing obligation from the date of this certification through the date of contract award by school district to notify the school district in writing of any changes to the information contained herein; that I am aware that it is a criminal offense to make a false statement or misrepresentation in this certification, and if I do so, I am subject to criminal prosecution under the law and that it will constitute a material breach of my agreement(s) with the school district permitting the school district to declare any contract(s) resulting from this certification void and unenforceable.</p> | | | |
| Full Name (Print): | | Title: | |
| Signature: | | Date: | |

List of Subcontractors

Contact _____
(Please Print)

Company Name _____

Address _____

Phone: _____ Fax: _____

E-mail _____

Contact _____
(Please Print)

Company Name _____

Address _____

Phone: _____ Fax: _____

E-mail _____

Contact _____
(Please Print)

Company Name _____

Address _____

Phone: _____ Fax: _____

E-mail _____

No Subcontractors will be used on this project _____

Signature _____

Name (print or type) _____

Title _____

Name of Firm _____

Project References

The following projects are in the process or have been completed by the contractor within the last five years and are comparable in type of work and costs to the project herein.

Project and Location

Date of Completion

Project Description and Cost

Signature_____

Name (print or type)_____

Title_____

Name of Firm_____

Montgomery Township Board of Education

ACKNOWLEDGMENT OF RECEIPT OF ADDENDA

The undersigned hereby acknowledges receipt of the following Addenda:

| <u>Addendum Number</u> | <u>Dated</u> | <u>Acknowledge Receipt</u> (initial) |
|------------------------|--------------|-----------------------------------------|
| _____ | _____ | _____ |
| _____ | _____ | _____ |
| _____ | _____ | _____ |
| _____ | _____ | _____ |

_____ **No Addenda Received**

Acknowledged for: _____
(Name of Bidder)

By: _____
(Signature of Authorized Representative)

Name: _____
(Print or Type)

Title: _____

Date: _____

**MONTGOMERY TOWNSHIP BOARD OF EDUCATION
1014 ROUTE 601
SKILLMAN, NEW JERSEY 08558
PHONE: (609) 466-7601
FAX: (609) 466-0944**

B22-02, Annual Boiler Cleaning, Inspection and Service with a Time and Material Contract

Specifications

The intent of this specification is to establish minimum requirements upon which solicitation of bids will be accepted for annual boiler cleaning, inspection and service with a time and material contract including parts and materials as needed for the Montgomery Township Board of Education.

Scope of Work

The contractor shall shut down and isolate, lock out and tag out, as needed all equipment to be worked on.

Drain boilers down, open the watersides of all boilers, including hand hole, man ways and all low water cut offs and piping flush the watersides clean removing all mud and scale build up. Leave open for inspection.

Buildings where reheat for air conditioning is required, will have one (1) boiler done at a time.

Open the firesides of each boiler, wire brush and power vacuum clean all tubes and flue passages as required; leave open for inspection.

Written report is required for each boiler listing any potential or recommended repairs followed by written quotation if needed to the Director of Facilities.

Upon completion of inspection, all boilers are to be closed using all new gasketing materials. All bolts reinstalled are to be coated with "Neverseez."

The contractor shall be fully capable of servicing Aerco Benchmark, Fulton and KC type boilers and must provide a certificate of training with your bid.

All Aerco Benchmark boilers are to have burners removed and inspected for damaged and worn igniters and flame sensors are to be removed and replaced, along with new burner and burner release gaskets when burner is reinstalled. Condensate traps and piping are to be opened, inspected and cleaned.

All heating and domestic boilers are to have burners completely serviced as per manufacturers' recommendations and calibrated for maximum efficiency.

Combustion efficiency low nox testing is to be performed with printouts of all results being provided to the Director of Facilities.

All boiler operating and safety controls are to be tested, verified operational on written service order reports and provided to the Director of Facilities.

The contractor shall be a fully insured and licensed boiler repair contractor in the State of New Jersey. A copy of your boiler repair license must be provided with your bid.

The contractor shall open and inspect the fireside and waterside of all units. Dismantle; clean, repair and service burners including all belts and filters for proper efficiency and operation. Then fire and test for efficiency. Check all operating and safety controls for safe and proper operation. Repair and/or replace controls if found to be defective.

Dismantle low water cut off, drain system on cast iron boiler and clean mud drums waterside. On all boilers remove all waterside access openings and flush system, clean and reassemble with new gaskets, and check operation. Replace all sites glass where needed. Repair and replace fire brick in all boilers where repair and replacement is required, assuring fire chamber is in proper operating condition.

All units must be left open for our insurance carrier's inspection and closed upon completion of the inspection.

Any major repairs and/or replacement of burner or boiler parts necessary for proper operation shall be brought to the attention of the Director of Facilities. Separate quotations may be required prior to initiating any corrections or additional work

A complete written report of each unit is to be provided to the Director of Facilities prior to our insurance carrier's inspection.

If applicable, all boiler soot is to be removed in an approved Department of Environmental Protection vehicle and dumped at an Authorized Transfer Station in accordance with all laws and regulations. Also, copies of the dumping receipt must be provided to the Montgomery Township Board of Education before payment for the work performed will be made.

The contractor shall provide all required information and assist the Director of Facilities in the preparation of certification to operate control apparatus or equipment forms as required by the State of New Jersey. This shall apply to all applicable equipment.

General

- A. If applicable, the contractor shall obtain all necessary permits that are required to perform the work. The contractor shall also pay any and all permit fees that cannot be waived by the Montgomery Township Board of Education. The contractor shall advise the Montgomery Township Board of Education of the necessary permits that are needed so a waiver can be requested in ample time before the start of the project. The contractor shall set-up all required inspections with the proper governing officials prior, during and upon completion of the work and provide a Certification of Inspection to the Montgomery Board of Education.
- B. The contractor shall set-up a mutually agreeable time with the Director of Facilities for the start of the project. No work shall be performed without making prior arrangements with the Director of Facilities and the Montgomery Township Board of Education. The Montgomery Township Board of Education reserves the right to delay or change the project schedule for unforeseen reasons.
- C. The contractor shall provide all materials, equipment and labor that are necessary for the completion of the project. All the materials used shall be as environmentally safe as is technologically possible. The application practices used are to be as per all manufactures requirements. The contractor shall follow all applicable laws and regulations concerning the safe application of all materials used in the performance of the job.
- D. Any and all asbestos containing materials that may be near the work area are to be avoided and shall be left undisturbed. All employees of the contractor must have Asbestos Awareness Training. The contractor is to provide documentation of training with their bid.

- E. The contractor shall take all necessary precautions during the project to effectually protect all parties from injury and property damage, and shall be liable for such damage or injury until the project is fully completed, approved, and accepted by the owner.
- F. All work shall be performed in a neat and workmanlike manner. The contractor is to perform all necessary touch-ups that may be needed. The work area shall be kept orderly and in a clean and neat condition during each workday and at completion of the project. The contractor shall, as necessary, make provision for a safe work area for all building occupants and visitors.
- G. The contractor shall be responsible for the removal and proper disposal of all excess materials, trash and/or debris generated from this project according to all-existing disposal laws and regulations. When possible the material should be recycled when permitted by law. If a dumpster is required for disposal, the contractor shall check with the building management representative for approval of its placement.
- H. Contractor personnel are to follow all district health and safety policies and shall refrain from smoking on district property.
- I. The contractor must supply the district with an example of insurance with their bid.
- J. Upon completion of the job and prior to payment the contractor shall attend a post job meeting and walk through with the Director of Facilities at which time a list of any and all problems and concerns will be formulated and addressed. All punch list items must be addressed and accepted before payment will be issued.

Montgomery Township Board Of Education - Boiler Listing

May 2021

| Location | Unit No. | Make | Year | BTU | Model | Serial Number | National Board of Boiler | NJ Registration |
|-------------------------|-------------|--------------|------|-----------|--------------------------|---------------|------------------------------|-----------------|
| MHS Boiler RM | 1 | Aerco | 2004 | 2,000,000 | Benchmark 2.0 Low NOX | G-03-0935 | NB 39346 | NJ092236-07H |
| MHS Boiler RM | 2 | Aerco | 2004 | 2,000,000 | Benchmark 2.0 Low NOX | G-03-0931 | NB 39337 | NJ092965-07H |
| MHS Boiler RM | 3 | Aerco | 2004 | 2,000,000 | Benchmark 2.0 Low NOX | G-03-0934 | NB 39345 | NJ092972-07H |
| MHS Boiler RM | 4 | Aerco | 2004 | 2,000,000 | Benchmark 2.0 Low NOX | G-03-0930 | NB 39336 | NJ092970-07H |
| MHS Boiler RM | 5 | Aerco | 2004 | 2,000,000 | Benchmark 2.0 Low NOX | G-03-0928 | NB 39334 | NJ092966-07H |
| MHS Boiler RM | 6 | Aerco | 2004 | 2,000,000 | Benchmark 2.0 Low NOX | G-03-0936 | NB 39347 | NJ092964-07H |
| MHS Boiler RM | 7 | Aerco | 2004 | 2,000,000 | Benchmark 2.0 Low NOX | G-03-0933 | NB 39344 | NJ092967-07H |
| MHS Boiler RM | 8 | Aerco | 2004 | 2,000,000 | Benchmark 2.0 Low NOX | G-03-0929 | NB 39335 | NJ092968-07H |
| MHS Boiler RM | 9 | Aerco | 2004 | 2,000,000 | Benchmark 2.0 Low NOX | G-03-0927 | NB 39333 | NJ092971-07H |
| MHS Boiler RM | 10 | Aerco | 2004 | 2,000,000 | Benchmark 2.0 Low NOX | G-03-0932 | NB 39338 | NJ092969-07H |
| MHS Boiler RM | BP-1 | Aerco | 2014 | 2,000,000 | Innovation 1060 | G-14-1427 | NB 68482 | |
| MHS Boiler RM | BP-3 | Aerco | 2014 | 2,000,000 | Innovation 1060 | G-14-1429 | NB 68434 | |
| MHS Boiler RM | BP-5 | Aerco | 2014 | 2,000,000 | Innovation 1060 | G-14-1428 | NB 68433 | |
| MHS Boiler RM | BP-7 | Aerco | 2014 | 2,000,000 | Innovation 800 | G-14-1365 | NB 68369 | |
| MHS Boiler RM | BP-9 | Aerco | 2014 | 2,000,000 | Innovation 800 | G-14-1364 | NB 68368 | |
| BOE Boiler RM | 11 | Aerco | 2004 | 2,000,000 | Benchmark 2.0 Low NOX | G-02-0984 | NB 37884 | NJ039853-07H |
| BOE Boiler RM | 12 | Aerco | 2004 | 2,000,000 | Benchmark 2.0 Low NOX | G-02-0983 | NB 37883 | NJ085319-07H |
| UMS Boiler RM | 1 | Aerco | 2009 | 2,000,000 | Benchmark 2.0 Low NOX | G-08-1411 | | NJ073007-09H |
| UMS Boiler RM | 2 | Aerco | 2009 | 2,000,000 | Benchmark 2.0 Low NOX | G-08-1409 | | NJ073008-09H |
| UMS Boiler RM | 3 | Aerco | 2009 | 2,000,000 | Benchmark 2.0 Low NOX | G-08-1408 | | NJ073009-09H |
| UMS Boiler RM | 4 | Aerco | 2009 | 2,000,000 | Benchmark 2.0 Low NOX | G-08-1410 | | NJ073007-09H |
| LMS Boiler RM (rear) | 1 | Fulton | 2017 | 3,000,000 | Fulton Hydronic EDR 3000 | 0003 | | |
| LMS Boiler RM (rear) | 2 | Fulton | 2017 | 3,000,000 | Fulton Hydronic EDR 3000 | 122981 | | |
| LMS Boiler RM (front) | 1 | Burnham | 1997 | 2,710,000 | 3W-60-50-G0-BMN | 24271 | NB24271 | NJ084188-07H |
| LMS Boiler RM (front) | 2 | Burnham | 1997 | 2,710,000 | 3W-60-50-G0-BMN | 24272 | NB24272 | NJ084184-07H |
| Village | 1 thru 8 | HydroTherm | 1999 | 2,440,000 | MultiTemp MG-3080 | MVG-1275 | | NJ000022486H |
| Village | 1B,3B,5B,7B | HydroTherm | 2000 | 1,220,000 | MultiTemp MG-3080 | MVG-1315 | | NJ000025461H |
| Village | 2B,4B,6B,8B | HydroTherm | 2000 | 1,220,000 | MultiTemp MG-3080 | MVG-1315 | | NJ000025460H |
| OHES Boiler RM (west) | 1 | Aerco | 2011 | 3,000,000 | Benchmark 3.0 Low NOX | G-11-0660 | NB58246 | NJ121213-12H |
| OHES Boiler RM (west) | 2 | Aerco | 2011 | 3,000,000 | Benchmark 3.0 Low NOX | G-11-0661 | NB58244 | NJ121214-12H |
| OHES Boiler RM (center) | 1 | Fulton | 2017 | 3,000,000 | Fulton Hydronic EDR 1500 | 121914 | | |
| OHES Boiler RM (center) | 2 | Fulton | 2017 | 3,000,000 | Fulton Hydronic EDR 1500 | 121925 | | |
| OHES Boiler RM (east) | 2 | Hydro Therm | 2007 | 2,000,000 | Benchmark 2.0 Low NOX | G-07-1306 | NB48181 | NJ102263-07H |
| OHES Boiler RM (east) | 1 | Hydro Therm | 2007 | 2,000,000 | Benchmark 2.0 Low NOX | G-07-1307 | NB48182 | NJ102264-07H |
| Bus Garage | 1 | HB Smith | 1979 | 250,000 | Cast Iron Type | L79-149 | CHB0047 | NJ06860-07H |
| Maintenance Garage | 1 | Comfortmaker | 1988 | 100,000 | GU-400100 | R-883900273 | Gas Furnace - Forced Hot Air | |

MAINTENANCE

Chapter 7 - MAINTENANCE

7.1 MAINTENANCE SCHEDULE

The unit requires regular routine maintenance to keep up efficiency and reliability. For best operation and life of the unit, the following routine maintenance procedures should be carried out in the time periods specified.

See Appendix I for complete CSD-1 inspection check list

WARNING!

TO AVOID PERSONAL INJURY, BEFORE SERVICING:

- (A) DISCONNECT THE AC SUPPLY BY TURNING OFF THE SERVICE SWITCH AND AC SUPPLY CIRCUIT BREAKER
- (B) SHUT OFF THE GAS SUPPLY AT THE MANUAL SHUT-OFF VALVE PROVIDED WITH THE UNIT
- (C) ALLOW THE UNIT TO COOL TO A SAFE TEMPERATURE TO PREVENT BURNING OR SCALDING

7.2 SPARK IGNITOR

The spark ignitor assembly is located in the body of the burner (see Fig. 7.1). The ignitor may be HOT. Care should be exercised. It is easier to remove the ignitor from the unit after the unit has cooled to room temperature.

To inspect/replace the Ignitor:

1. Set the ON/OFF switch on the control panel, to the OFF position. Disconnect AC power from the unit.
2. Remove the side and top panels from the unit.
3. Disconnect the ignitor cable from the ignitor contactor and pull the ignitor bushing from the burner shell.
4. Insert the ignitor removal tool into the burner shell, where the ignitor bushing was removed. Fit the hexagonal end of the tool over the ignitor. (See Fig. 7.2) Unscrew the ignitor from the burner head. Remove the ignitor from the burner shell, by grasping the contact end of the ignitor.

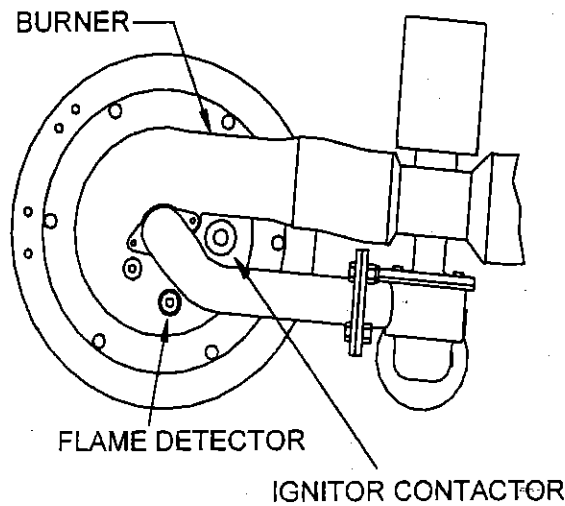

Figure 7.1
Spark Ignitor and Flame Detector Location
Top View

CAUTION!

The ignitor may be hot

5. The ignitor is gapped at 1/8-inch. If there is a substantial erosion of the spark gap or ground electrode, the ignitor should be replaced. If carbon build-up is present, clean the ignitor using fine emery cloth. Repeated carbon build-up on the ignitor is an indication that a check of the combustion settings is required (see Chapter 4 for combustion calibration).
6. Prior to reinstalling the ignitor, an anti-seize compound must be applied to the ignitor threads.

CAUTION!

The ignitor must be removed and installed using the ignitor removal tool provided with the unit(s). Damage to the burner due to using a socket for removal and installation of the ignitor is not covered under warranty.

7. Reinstall the ignitor using the ignitor removal tool. Do not over tighten the ignitor. A slight snugging up is sufficient. Reinstall the ignitor bushing over the contactor and reconnect the ignitor cable.
8. Reinstall the side and top panels on the unit.

MAINTENANCE

Table 1 - Maintenance Schedule

| PARAGRAPH | ITEM | 6 Mos. | 12 Mos. | 24 Mos. | Labor Time |
|-----------|---------------------------|----------|-----------------------------|------------------------------|------------|
| 7.2 | Spark Ignitor | *Inspect | Replace | | 15 mins. |
| 7.3 | Flame Detector | *Inspect | Replace | | 15 mins. |
| 7.4 | Combustion Adj. | *Check | Check | | 1 hr. |
| 7.5 | Testing of Safety Devices | | See CSD-1 Chart in Appendix | | 20 mins. |
| 7.6 | Burner | | | Inspect | 2 hrs. |
| 7.7 | **Manifold & Tubes | | | Inspect & clean if necessary | 4 hrs. |

* Only performed after initial 6 month period after initial startup.

** Recommended only when unit will be run in an extreme condensing mode for prolonged periods of time.

7.3 FLAME DETECTOR

The flame detector assembly is located in the body of the burner (see Fig. 7.1). The flame detector may be HOT. Allow the unit to cool sufficiently before removing the flame detector.

To inspect or replace the flame detector:

1. Set the **ON/OFF** switch on the control panel, to the **OFF** position. Disconnect AC power from the unit.
2. Remove the side and top panels from the unit.
3. Disconnect the flame detector lead wire. Unscrew the flame detector and remove it. (See Fig 7.2)
4. Inspect the detector thoroughly. If eroded, the detector should be replaced. Otherwise clean the detector with a fine emery cloth.
5. Reinstall the flame detector hand tight only.
6. Reconnect the flame detector lead wire.
7. Reinstall the side and top panels on the unit.

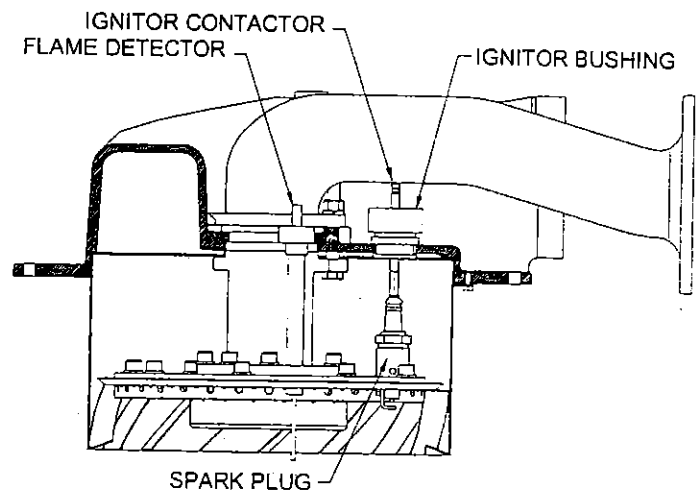

Figure 7.2
Spark Ignitor and Flame Detector Location
Cut-Away View

7.4 COMBUSTION CALIBRATION

Combustion settings must be checked at the intervals shown in Table 1 as part of the maintenance requirements. Refer to Chapter 4 for combustion calibration instructions.

MAINTENANCE

7.5 SAFETY DEVICE TESTING

Systematic and thorough tests of the operating and safety devices should be performed to ensure that they are operating as designed. Certain code requirements, such as ASME CSD-1, require that these tests be performed on a scheduled basis. Test schedules must conform to local jurisdictions. The results of the tests should be recorded in a logbook. See Chapter 6- Safety Device Testing Procedures.

7.6 BURNER

The burner assembly is located at the top of the unit. The burner assembly may be HOT. Allow the unit to cool sufficiently before removing the burner assembly.

The following parts will be necessary for reassembly after inspection:

| | |
|--------|-----------------------|
| 161432 | Burner Gasket |
| 161433 | Burner Release Gasket |

To inspect or replace the burner assembly:

1. Set the ON/OFF switch on the control panel to the OFF position and disconnect AC power to the unit and turn off the gas supply.
2. Remove the side and top panels from the unit.
3. Disconnect the lead wire from the flame detector.
4. Disconnect the ignitor cable from the ignitor contactor.
5. Disconnect the combustion air hose from the burner by loosening the hose clamp. (See Fig. 7.3)
6. Remove the four (4) 5/8-11 nuts and bolts from the gas outlet side of the Air/Fuel Valve. (See Fig 7.3).

NOTE:
Do not remove the burner gas pipe from the burner. (See Fig. 7.3)

7. Remove the six (6) 5/16-16 bolts from the burner flange. (See Fig 7.3)
8. Remove the burner from burner flange by pulling straight up.

9. Remove and replace the burner release gasket.
10. Remove and replace the burner gasket.
11. Beginning with the burner removed in step 8 of this paragraph, reinstall all the components in the reverse order that they were removed.

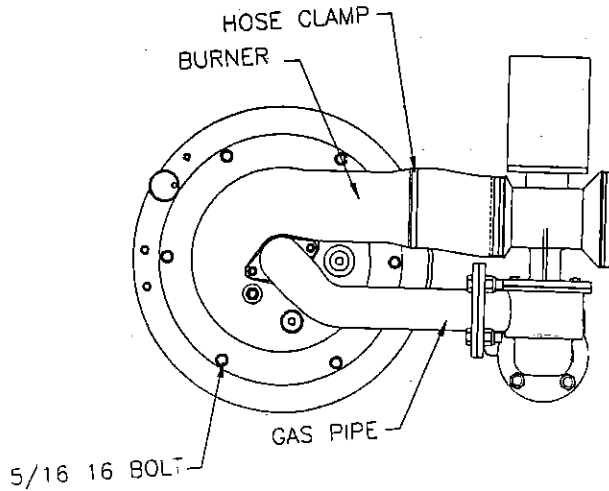

Figure 7.3
Burner Disassembly Diagram

NOTE:
The burner is heavy weighing approximately 25 pounds.

NOTE:
A complete inspection of the combustion chamber tubes can not be performed at this time. In order to completely inspect the combustion chamber tubes you must remove the exhaust manifold. (See Paragraph 7.7)

7.7 EXHAUST MANIFOLD AND COMBUSTION CHAMBER

The presence of even trace amounts of chlorides and/or sulfur, in the combustion air and fuel sources, can lead to the formation of deposits on the inside of the exchanger tubes, the exhaust manifold, and/or the condensate trap. The degree of deposition is influenced by the extent of the condensing operation and the chloride and sulfur levels. Even trace amounts of contaminants such as chlorides and sulfur void the warranty.

MAINTENANCE

The following parts will be necessary for reassembly after inspection:

| | |
|--------|-------------------------|
| 123612 | Exhaust Manifold Gasket |
|--------|-------------------------|

To remove the manifold for inspection:

1. Disconnect AC power and turn off the gas supply to the unit.
2. Disconnect and remove the condensate drain trap assembly from the exhaust manifold.
3. Disconnect the exhaust vent (flue) from the exhaust manifold outlet flange.

CAUTION!

The Exhaust Manifold Is Heavy. Do Not Drop The Exhaust Manifold While Removing The Mounting Bolts.

4. Remove the three (3) 1/2-13 mounting bolts from the exhaust manifold (See Fig 7.4).
5. Carefully lower the exhaust manifold and slide it out the rear of the unit

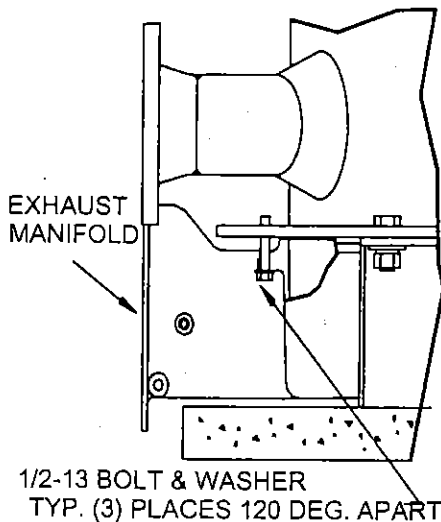

Figure 7.4
Exhaust Manifold Mounting Bolts

7. Remove and replace the exhaust manifold gasket.

8. Inspect the fire tubes for any signs of restriction or carbon build-up. Clean as necessary
9. Beginning with the exhaust manifold removed in step 7 of this paragraph reinstall all the components in the reverse order that they were removed.

7.8 SHUTTING THE BOILER DOWN FOR AN EXTENDED PERIOD OF TIME

1. If the boiler is to be taken out of service for an extended period of time, one year or more, the following instructions must be followed.
2. Set ON/OFF switch on the front panel to the OFF position to shut down the boiler's operating control.
3. Disconnect AC power from the unit.
4. Close supply and return valves to isolate boiler.
5. Close external gas supply valve.
6. Open relief valve to vent water pressure.

7.9 PLACING THE BOILER BACK IN SERVICE AFTER A PROLONGED SHUTDOWN

After a prolonged shutdown (a year or more), the following procedures must be followed:

1. Review installation requirements as shown in Chapter 2
2. Inspect all piping and connection to the unit
3. Inspect exhaust vent, air duct(if applicable) and
4. Gas regulator vent lines at their termination points. Check that they are clear and free of debris or pests.
5. Perform initial startup per Chapter 4
6. Perform safety device and maintenance procedures per Chapters 6 and 7 of this manual.

MONTGOMERY TOWNSHIP BOARD OF EDUCATION
1014 ROUTE 601
SKILLMAN, NEW JERSEY 08558
PHONE: (609) 466-7601 FAX: (609) 466-0944

PROPOSAL FORM

B22-02, Boiler Cleaning and Inspection with a Time and Material Contract

Due: **Tuesday, June 22, 2021 at 9:00 A.M.**

SPECIAL INSTRUCTIONS:

Contact period will be for a one-year period from **July 1, 2021** through **June 30, 2022** with the option for two one-year extensions from **July 1, 2022** through **June 30, 2023** and from **July 1, 2023** through **June 30, 2024** with the provision for no more than one two-year or two one-year extensions pursuant to N.J.S.18A:18A-42.

Contractor is willing to extend contract?

_____ Yes _____ No

The Montgomery Township Board of Education will not pay Travel Time. If the contractor wants to impose Travel Time charges it must be incorporated into the cost of the project and/or hourly labor rates.

All prices must include **shipping** and **handling charges**.

Exceptions to the specification should be noted.

The award will be made based on the total cost of the annual boiler cleaning, inspection and service, straight time per man/hour and the contractor's responsiveness to the specifications.

The successful contractor will be responsible for all work performed. In the event that the **contractor** subcontracts out any portion of this work the **contractor** will be the responsible contact of the Montgomery Township Board of Education.

When two or more contractors submit equal prices and the prices are the lowest responsible bid the Montgomery Township Board of Education may award the contract to the contractor whose response, in the discretion of the Board, is most advantageous, price and other factors considered.

Schools may be visited by appointment between 9:00 A.M. and 2:00 P.M., Monday through Friday. Please contact **Michael O'Neil, Director of Facilities** at **(609) 466-7601, Ext. 7012** for a site visit.

Please complete the following:

School Year 2021–2022

**Cost of Boiler Cleaning, Inspection and Service for the
Montgomery High School and Administration Office** \$ _____

**Cost of Boiler Cleaning, Inspection and Service for the
Upper Montgomery Middle School** \$ _____

Cost of Boiler Cleaning, Inspection and Service for the Lower Montgomery Middle School \$ _____
Cost of Boiler Cleaning, Inspection and Service for the Orchard Hill Elementary School \$ _____
Cost of Boiler Cleaning, Inspection and Service for the Village Elementary School \$ _____
Cost of Boiler Cleaning, Inspection and Service for the Bus Garage \$ _____
Cost of Boiler Cleaning, Inspection and Service for the Maintenance Garage \$ _____
Grand Total for Annual Boiler Cleaning, Inspection and Service \$ _____

Hourly rate for repairs:

July 1, 2021 through June 30, 2022

Straight Time (Monday thru Friday 8:00 AM to 5:00 PM) \$ _____ per man/hour.
 After Hours and Weekends..... \$ _____ per man/hour.
 Holidays..... \$ _____ per man/hour.

Cost of Replacement Parts _____% of Discount off List
 (Select option) _____% of Markup above List

Response Time in the event of an Emergency: _____ hr(s)

A written proposal for any additional repairs/recommendations must be submitted to Michael O'Neil, Director of Facilities. No work shall be performed without a hard copy authorized purchase order. All invoices for time and materials must include an itemized breakdown of hours, rates, materials and prices.

Exceptions to the specifications are _____

Company Name _____

Phone Number _____ Fax Number _____

Date _____

Authorized Signature _____

Contact Person _____

E-mail of Contact Person _____

E-mail where future quotes may be sent _____

***IT IS MANDATORY THAT THIS FORM BE COMPLETED, SIGNED AND SUBMITTED WITH YOUR
BID.***